

DH1~DH2=16171 (±20)

Coordinates

Mark	X	Y	R
GM	0	0	
DH1	-7900	-3000	
DH2	8234	-1900	
a1	-7569	-3828	300
a2	-7252	-4215	200
a3	-5914	-5092	200
a4	-5433	-5228	300
a5	4625	-5757	300
a6	5106	-5621	200
a7	6444	-4745	200
a8	6761	-4358	300
a9	4947	5546	300
a10	4697	6091	300
a11	2741	7166	300
a12	2157	7026	300

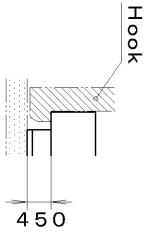
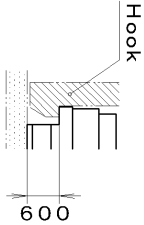
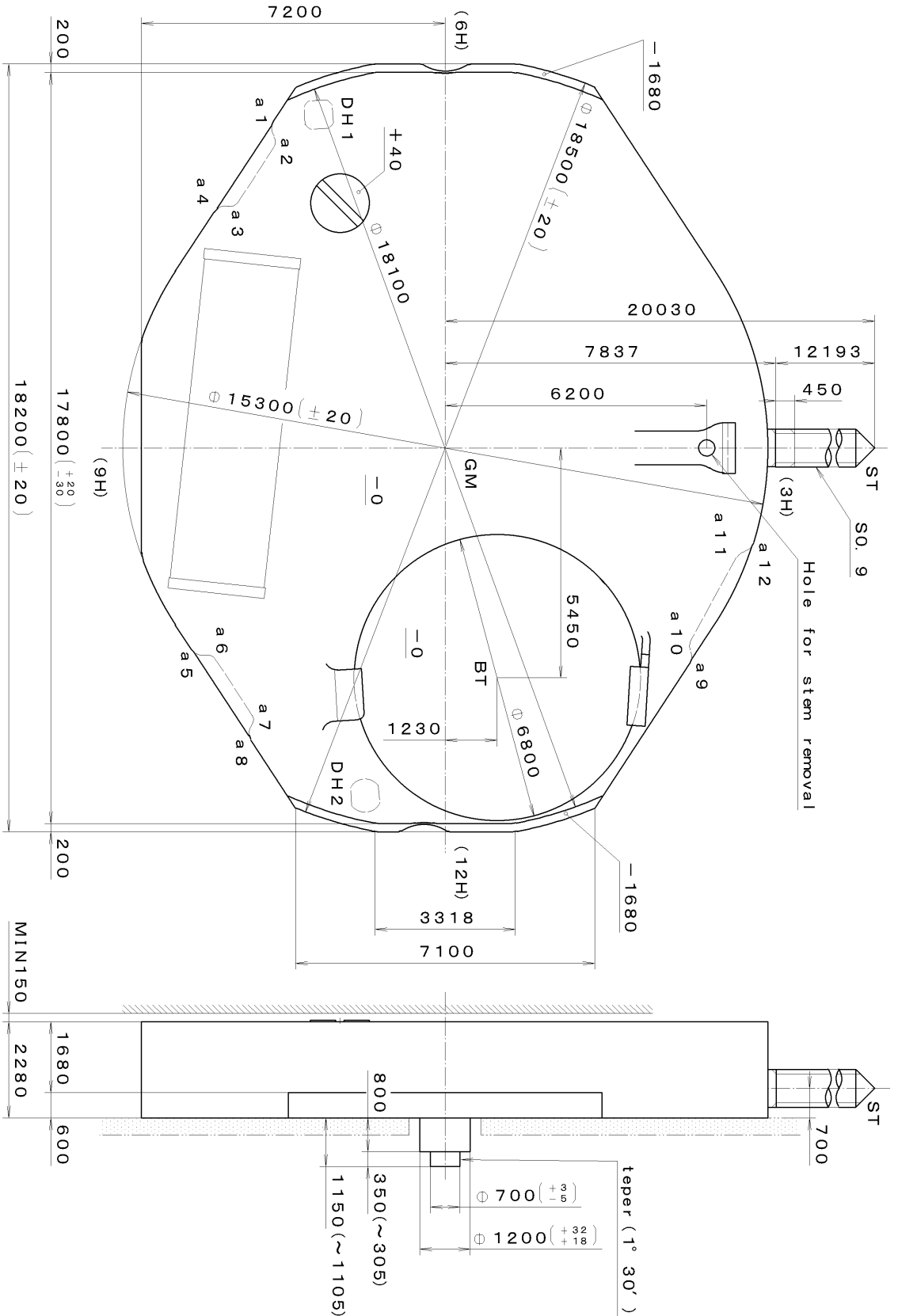

Section a1~a4, a5~a8

Section a9~a12

Material	GL20	Quantity	1/1000 mm	Cal. No. :	GL20
Heat Treatment		Unit	10:1	Parts:	
Hardness		Date		Checked	T. Hiruta
Plating		Drawn		Approved	
General Tolerances		Name :		Frame for Case	
Dimensions		Drawing No. :		GL20C0000	
Angles		Name :		Frame for Case	

CITIZEN WATCH CO., LTD.
TOKYO, JAPAN

DH1~DH2=16171 (±20)

Coordinates

Mark	X	Y	R
GM	0	0	
DH1	-7900	-3000	
DH2	8234	-1900	
a1	-7569	-3828	300
a2	-7252	-4215	200
a3	-5914	-5092	200
a4	-5433	-5228	300
a5	4625	-5757	300
a6	5106	-5621	200
a7	6444	-4745	200
a8	6761	-4358	300
a9	4947	5546	300
a10	4697	6091	300
a11	2741	7166	300
a12	2157	7026	300

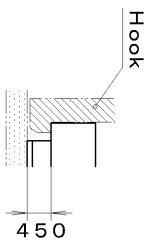
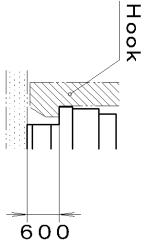
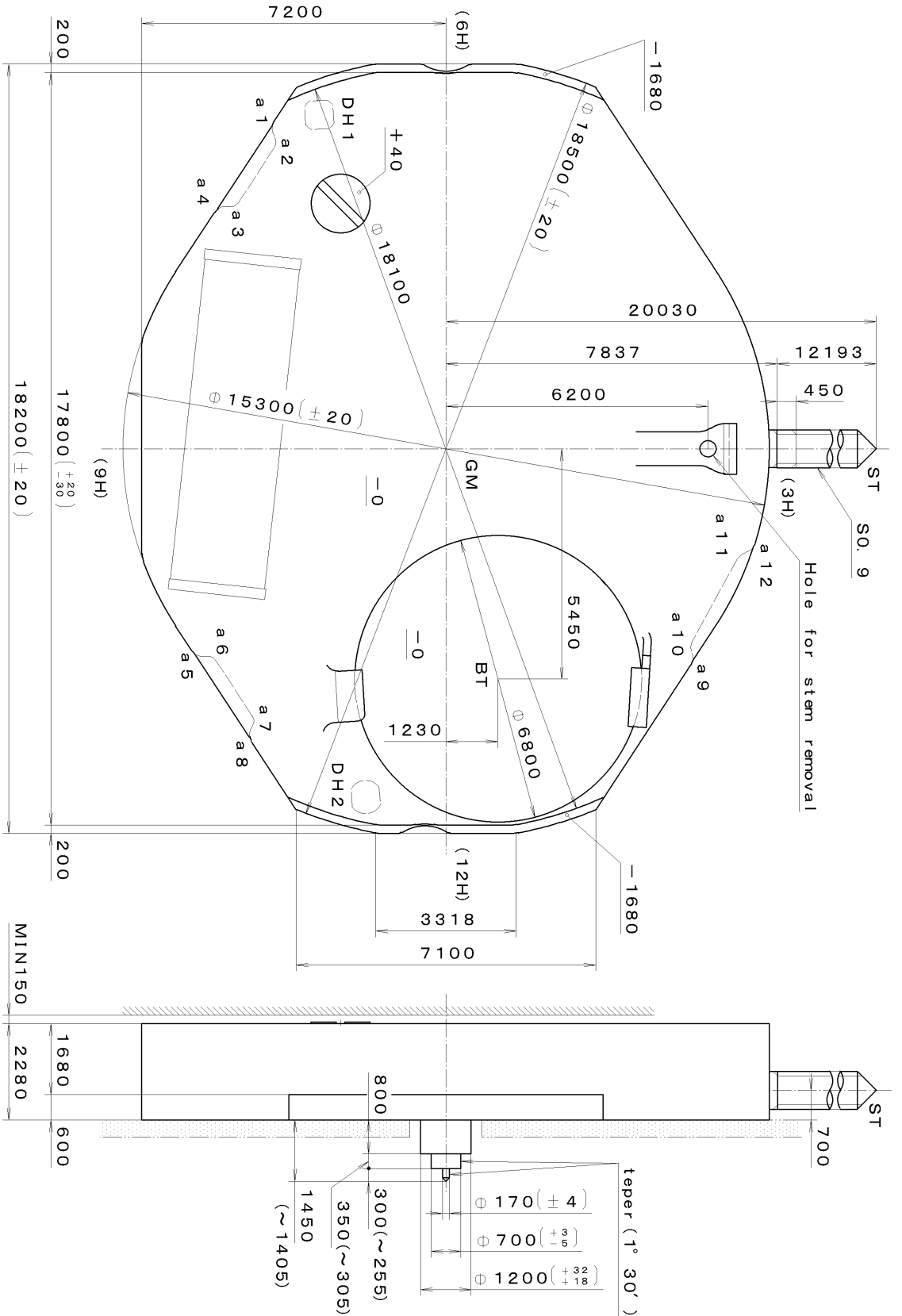

Section a1~a4, a5~a8

Section a9~a12

Material	GL30	Quantity	1/1000 mm	Cal. No. :	GL30
Heat Treatment		Unit		Parts:	
Hardness		Scale	10:1	Name :	Frame for Case
Plating		Date		Checked	T. Hiruta
		Drawn		Approved	
		General Tolerances		Drawing No. :	GL30C0000
		Dimensions			
		Angles			

CITIZEN WATCH CO., LTD. TOKYO, JAPAN

This drawing is provisional and subject to our reconfirmation and/or revision without notice.

*** T I P W 065-541 (01) *** (2100 1121) 02-07-12

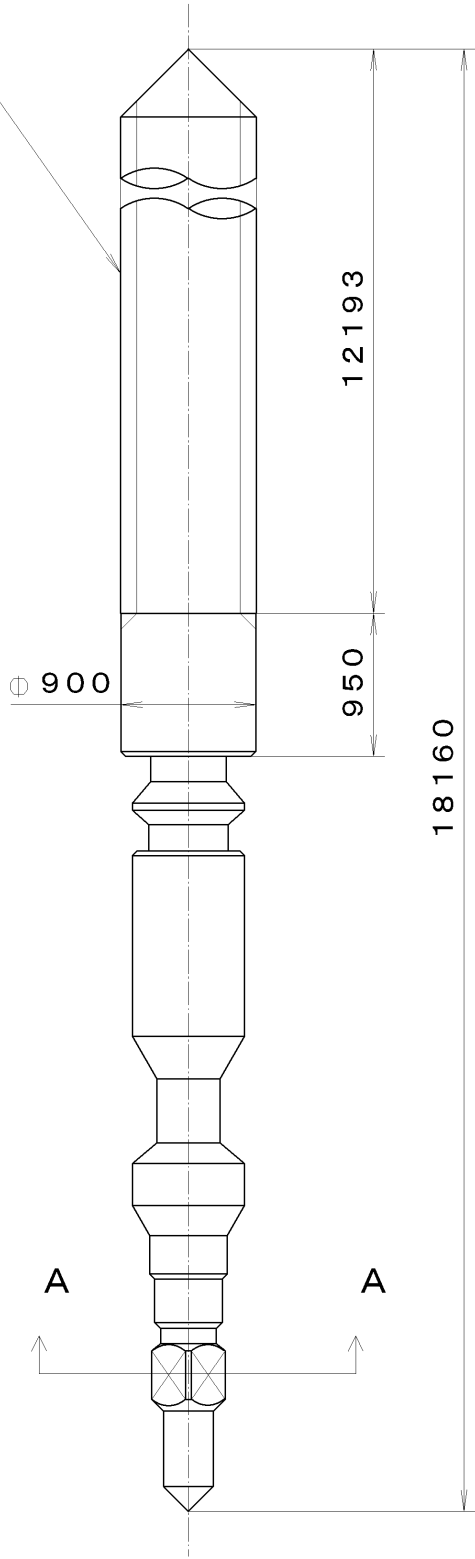
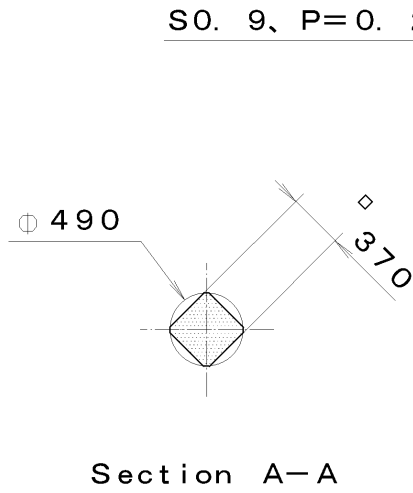

7			Quantity		Cal. No. :
6			Unit	1/1000 mm	Parts: 065-541
5			Scale	20:1	
4			Date		Name: SETTING STEM
3			Drawn		
2			Checked	T. Hiruta	
1			Approved		Drawing No. : 5410S000
Material			CITIZEN WATCH CO., LTD. TOKYO, JAPAN		
Heat Treatment					
Hardness					
Plating					
			General Tolerances		
			Dimensions		
			Angles		

DH1~DH2=16171 (±20)

Coordinates

Mark	X	Y	R
GM	0	0	—
DH1	-7900	-3000	—
DH2	8234	-1900	—
a1	3693	7119	530
a2	4431	6984	220
a3	5871	6041	220
a4	6325	5444	530
a5	6325	-5444	530
a6	5871	-6041	220
a7	4431	-6984	220
a8	3693	-7119	530
a9	-3693	-7119	530
a10	-4431	-6984	220
a11	-5871	-6041	220
a12	-6325	-5444	530
a13	-7331	4722	530
a14	-6923	5351	220
a15	-5488	6291	220
a16	-4760	6470	530

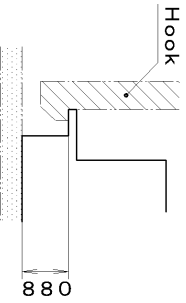
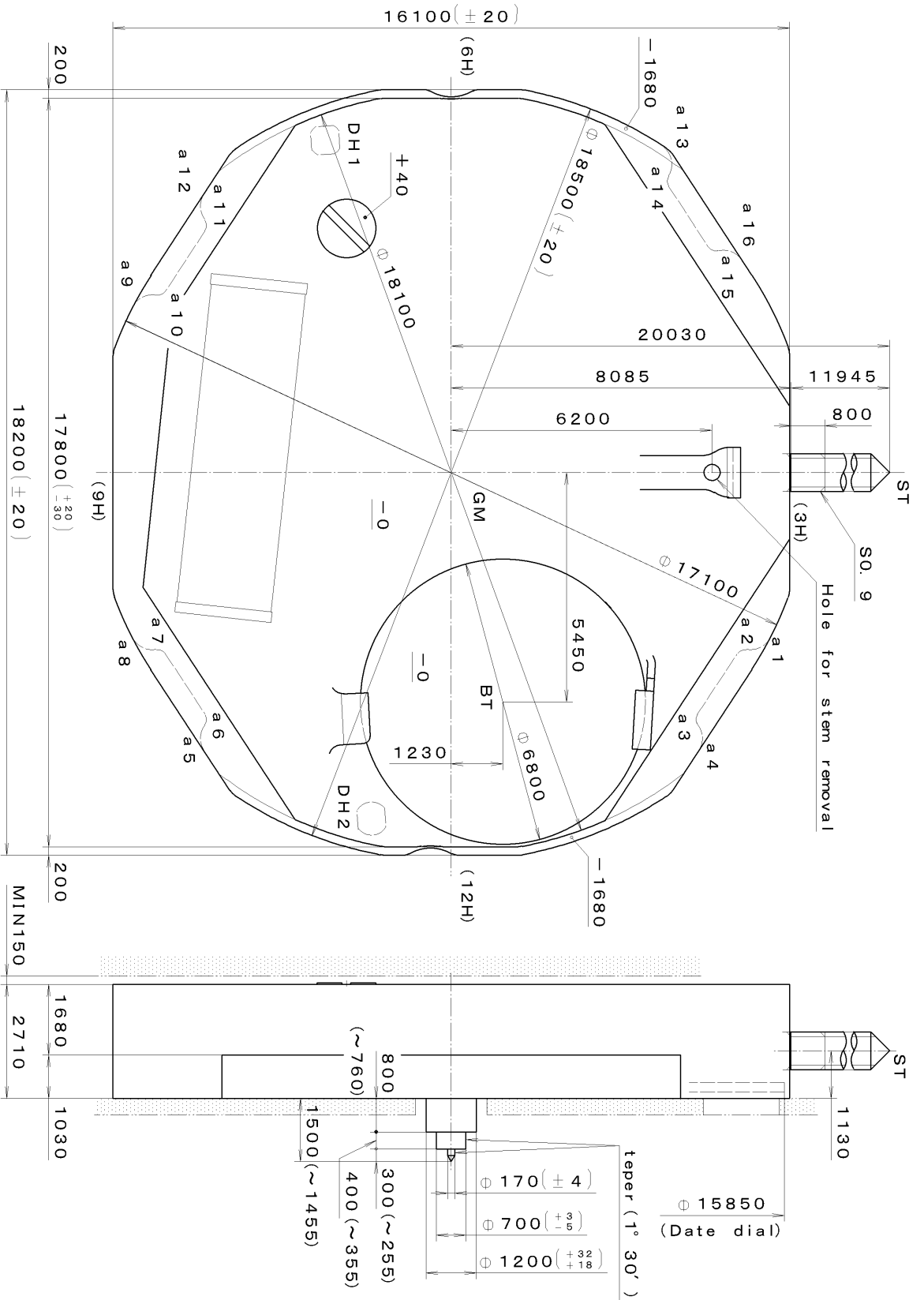

Section a1~a16

△	Quantity	1/1000 mm	Cal. No. : GL10
△	Unit	10:1	Parts:
△	Scale		Name: Frame for Case
△	Date		Drawing No. : GL10C0000
△	Drawn		
△	Checked	T. Hiruta	
△	Approved		
△	Material		
△	Heat Treatment		
△	Hardness		
△	Plating		
	General Tolerances		
	Dimensions		
	Angles		

CITIZEN WATCH CO., LTD.
TOKYO, JAPAN

DH1~DH2=16171 (±20)

Coordinates

Mark	X	Y	R
GM	0	0	
DH1	-7900	-3000	
DH2	8234	-1900	
a1	3693	7119	530
a2	4431	6984	220
a3	5871	6041	220
a4	6325	5444	530
a5	6325	-5444	530
a6	5871	-6041	220
a7	4431	-6984	220
a8	3693	-7119	530
a9	-3693	-7119	530
a10	-4431	-6984	220
a11	-5871	-6041	220
a12	-6325	-5444	530
a13	-7331	4722	530
a14	-6923	5351	220
a15	-5488	6291	220
a16	-4760	6470	530

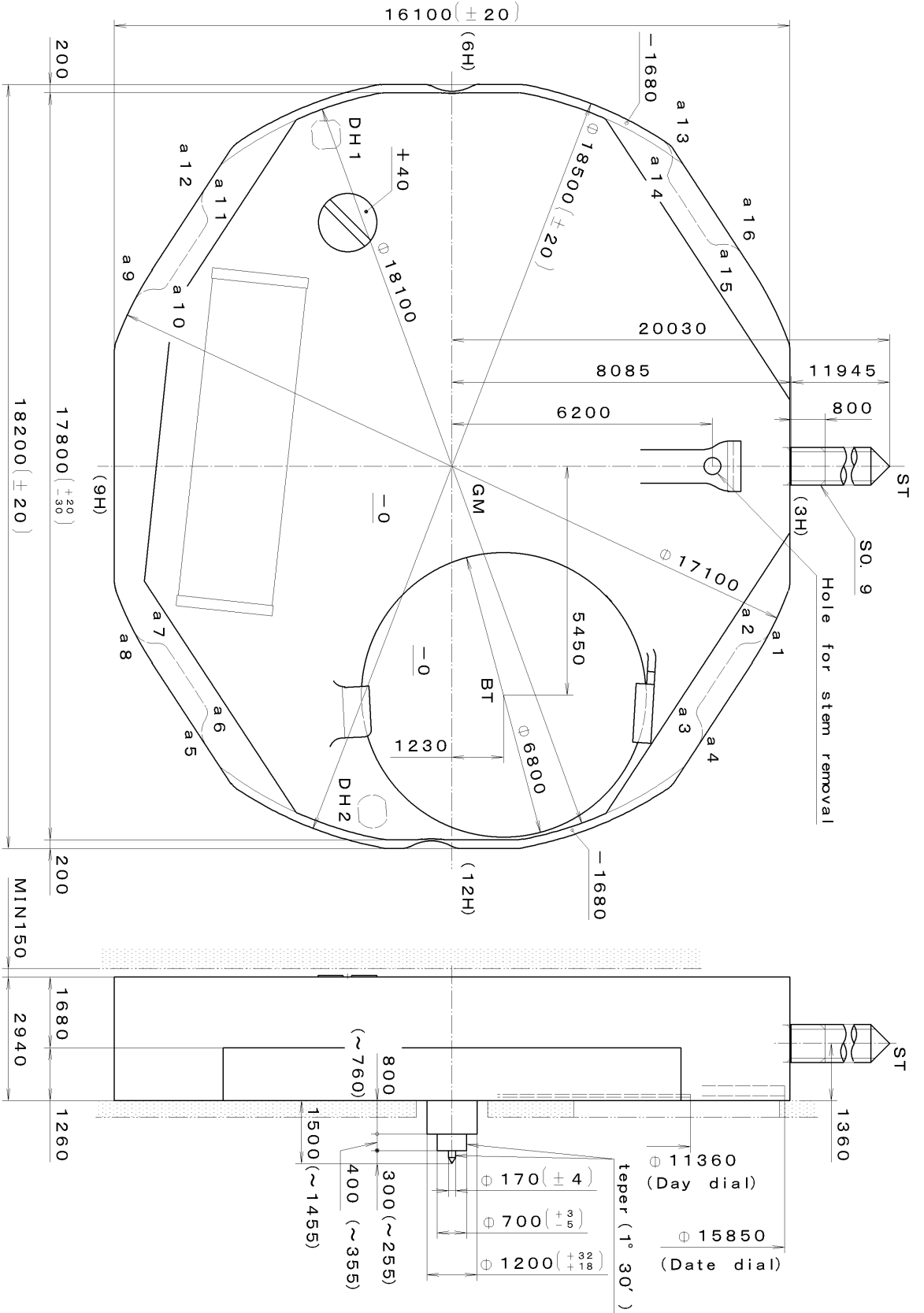

Section a1~a16

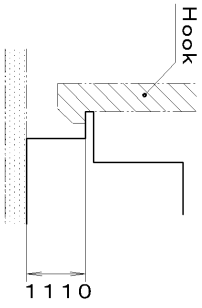

Quantity	Unit	1/1000 mm	Cal. No. : GLOO
Scale	10:1	Parts:	
Date	Drawn	Checked	Name : T. Hiruta
Material	Approved	Frame for Case	Drawing No. : GLOOCC000
Heat Treatment	General Tolerances		
Hardness	Dimensions		
Plating	Angles		

CITIZEN WATCH CO., LTD.
 TOKYO, JAPAN

This drawing is provisional and subject to our reconfirmation and/or revision without notice.

*** T I P W 065-547 (01) *** (2100 1121) 02-07-12

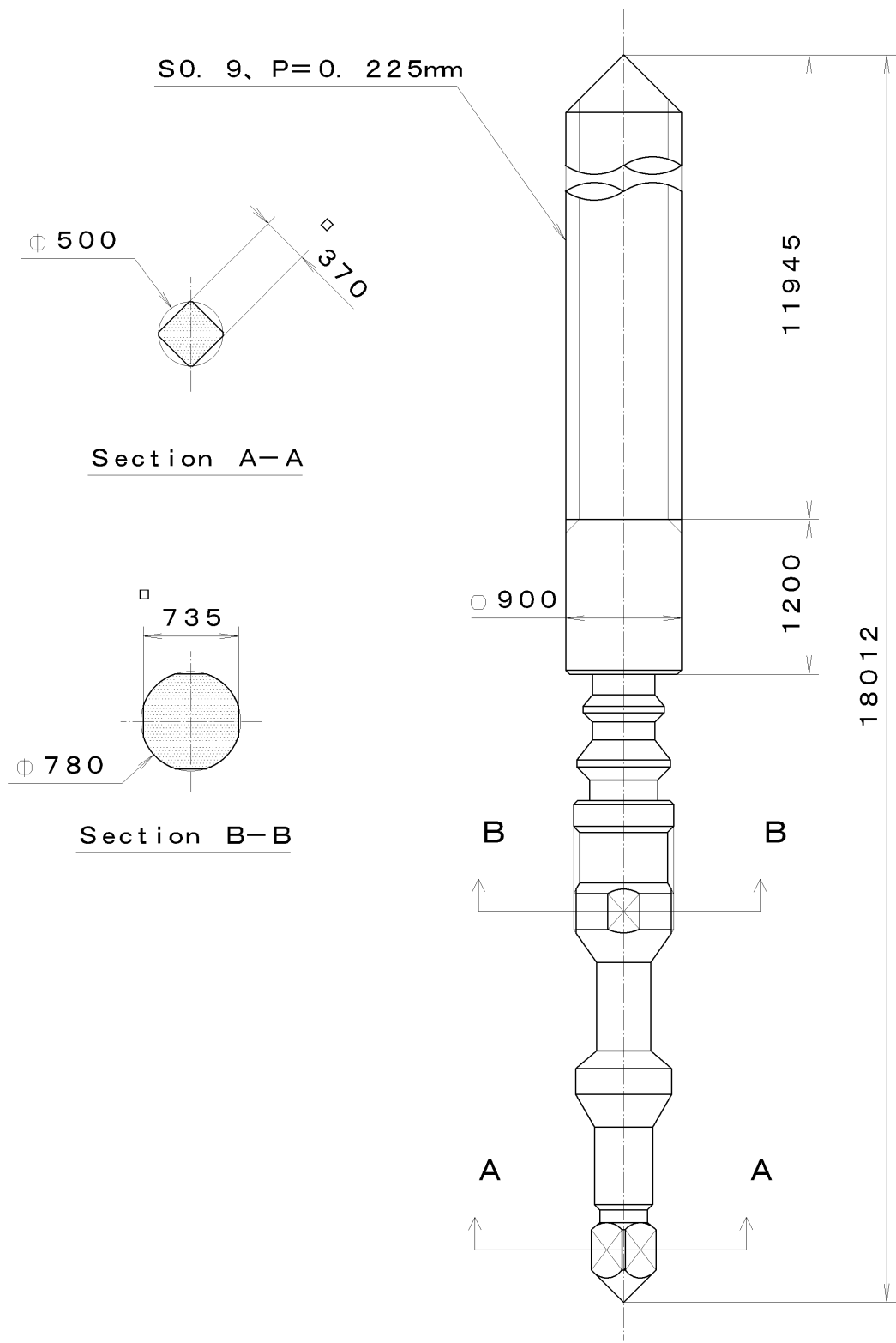

7			Quantity		Cal. No. :
6			Unit	1/1000 mm	
5			Scale	20:1	Parts:
4			Date		065-547
3			Drawn		
2			Checked	T. Hiruta	Name:
1			Approved		SETTING STEM
Material					Drawing No. : 5470S000
Heat Treatment			General Tolerances		CITIZEN WATCH CO., LTD. TOKYO, JAPAN
Hardness			Dimensions		
Plating			Angles		

DH3~DH4=22287 (±20)

Coordinates			
Mark	X	Y	R
GM	0	0	—
DH3	-8759	6900	—
DH4	8251	-7500	—
b1	7996	7871	530
b2	8624	7608	150
b3	10099	5501	150
b4	10131	4822	530
b5	7803	-8063	530
b6	7535	-8688	150
b7	5416	-10145	150
b8	4736	-10171	530
b9	-7996	-7871	530
b10	-8624	-7608	150
b11	-10099	-5501	150
b12	-10131	-4822	530
b13	-7803	8063	530
b14	-7535	8688	150
b15	-8416	10145	150
b16	-4736	10171	530

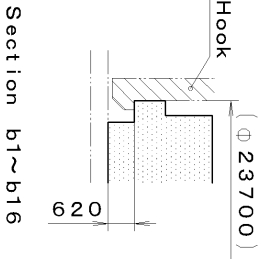
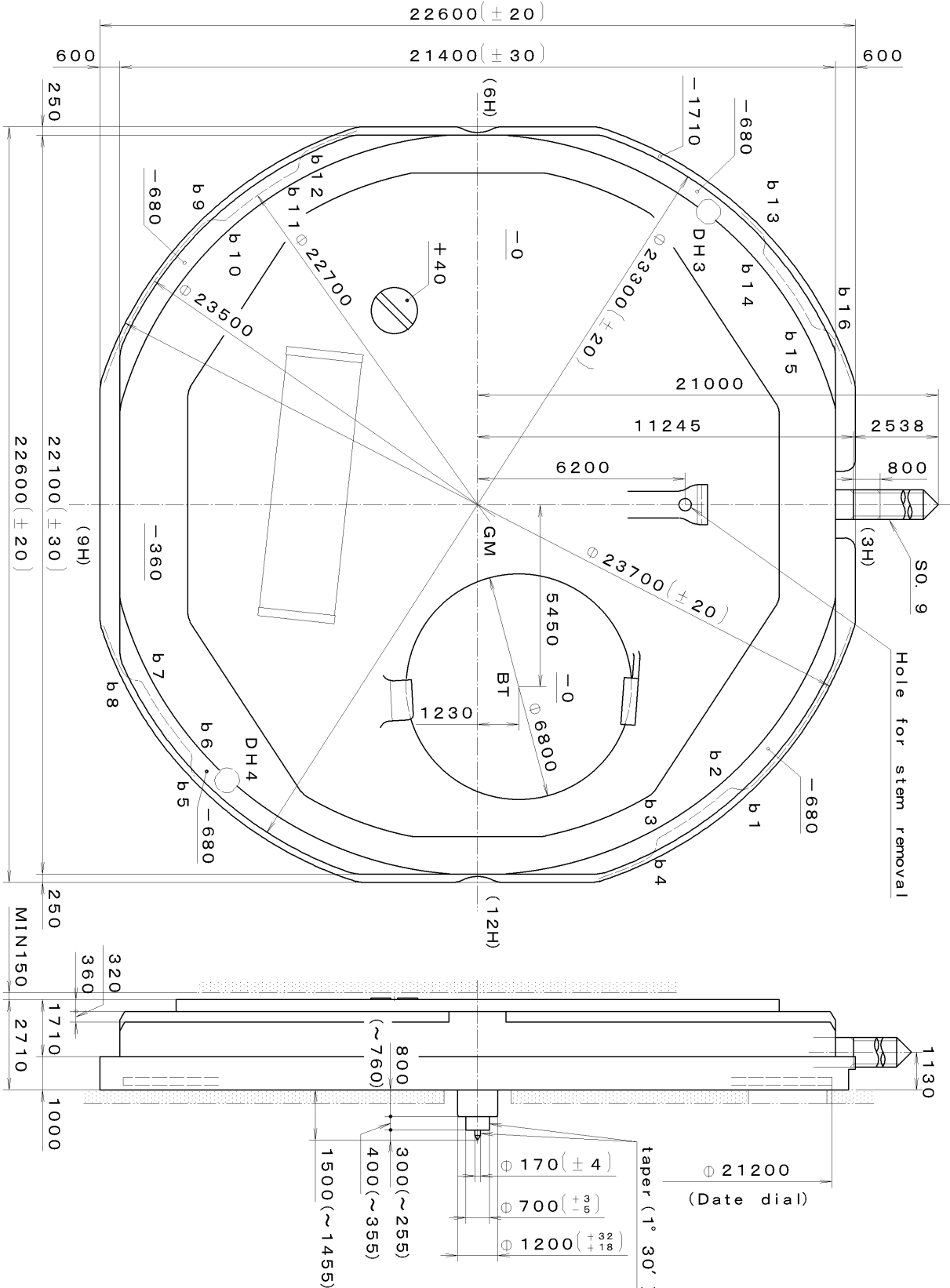

Quantity	Unit	Cal. No. :
1	1/1000 mm	GM10
1	8:1	Parts:
1	Date	Name:
1	Drawn	T. Hiruta
1	Checked	Frame for Case
1	Approved	Drawing No. : GM10C0000

Material	General Tolerances
Heat Treatment	Dimensions
Hardness	Angles
Plating	

CITIZEN WATCH CO., LTD.
TOKYO, JAPAN

*** TIPW GM00 (01) *** (2100 1121) 02-07-12

DH3~DH4=22287 (±20)

Coordinates			
Mark	X	Y	R
GM	0	0	---
DH3	-8759	6900	---
DH4	8251	-7500	---
b1	7996	7871	530
b2	8624	7608	150
b3	10099	5501	150
b4	10131	4822	530
b5	7803	-8063	530
b6	7535	-8688	150
b7	5416	-10145	150
b8	4736	-10171	530
b9	-7996	-7871	530
b10	-8624	-7608	150
b11	-10099	-5501	150
b12	-10131	-4822	530
b13	-7803	8063	530
b14	-7535	8688	150
b15	-8416	10145	150
b16	-4736	10171	530

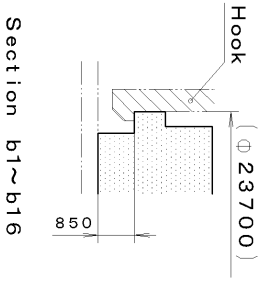

Section b1~b16

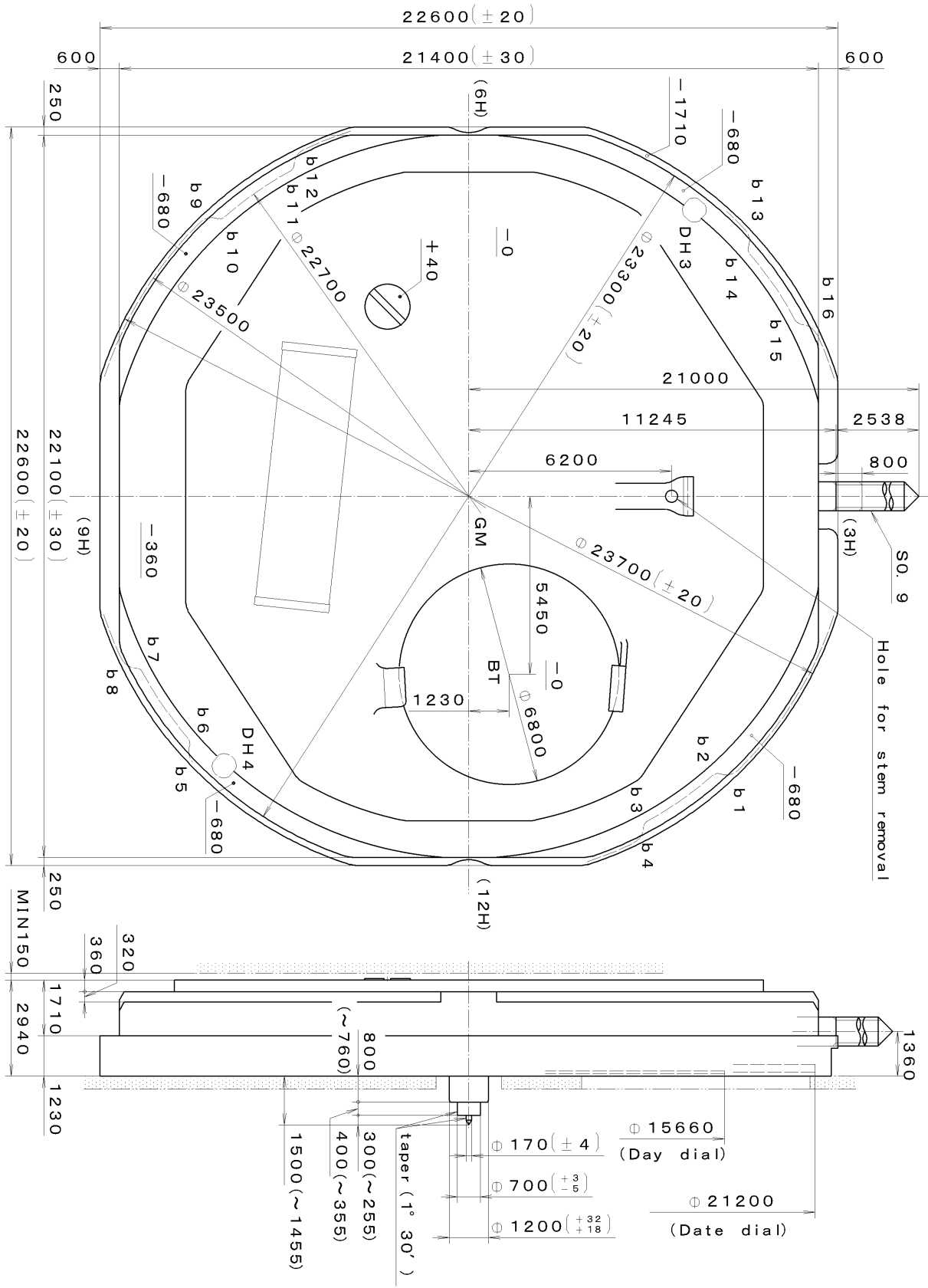

Material	Quantity	Unit	1/1000 mm	Cal. No. :	GM00
Heat Treatment		Scale	8:1	Parts:	
Hardness		Date		Checked	T. Hiruta
Plating		Drawn		Approved	
		Material			
		General Tolerances			
		Dimensions			
		Angles			
Name:					Frame for Case
Drawing No.:					GM00C000

CITIZEN WATCH CO., LTD.
 TOKYO, JAPAN

This drawing is provisional and subject to our reconfirmation and/or revision without notice.

*** T I P W 065-543 (01) *** (2100 1121) 03-05-07

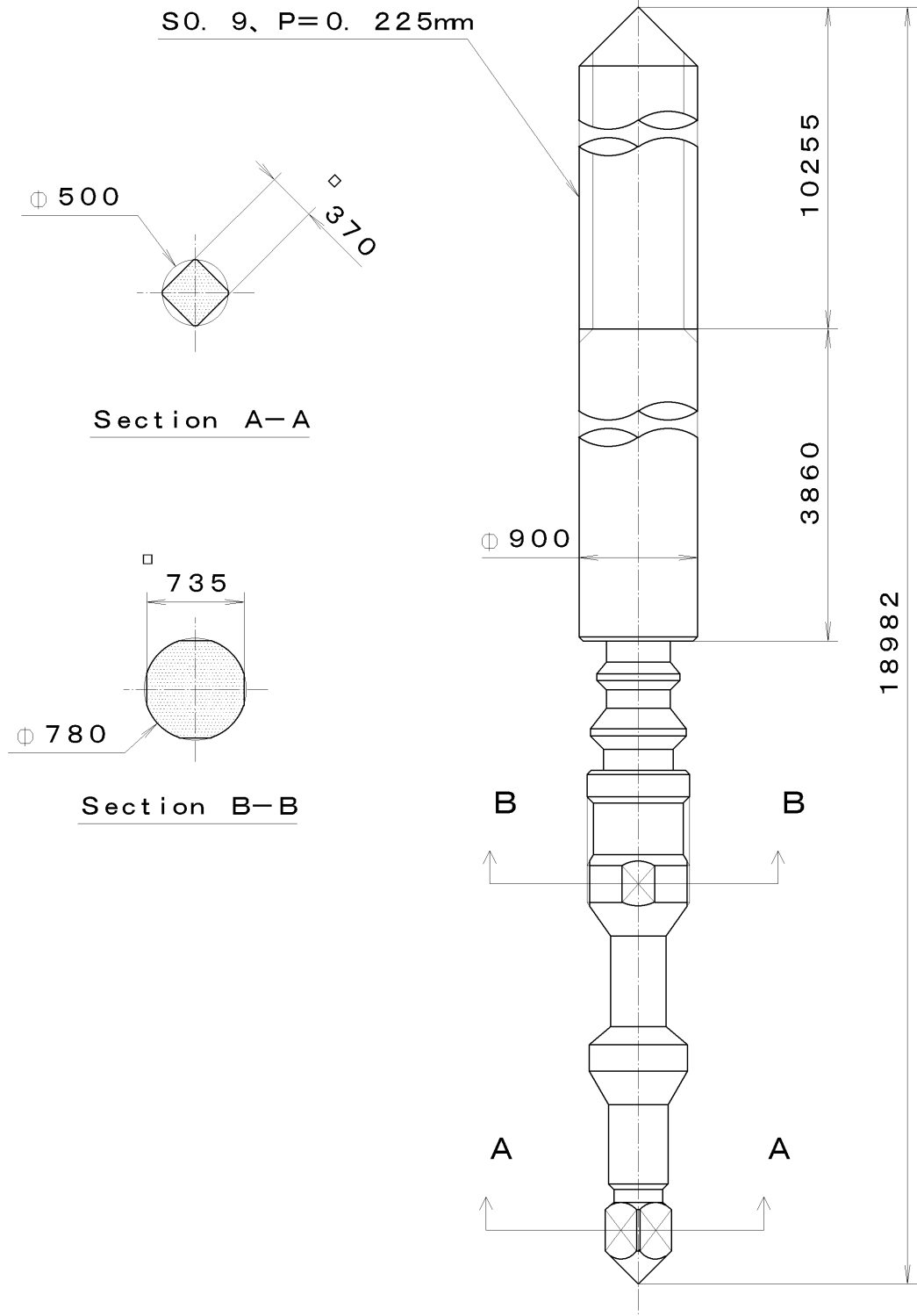

7			Quantity		Cal. No. :
6			Unit	1/1000 mm	
5			Scale	20:1	Parts:
4			Date		065-543
3			Drawn		
2			Checked	T. Hiruta	Name:
1			Approved		SETTING STEM
Material					Drawing No. : 5430S001
Heat Treatment			General Tolerances		CITIZEN WATCH CO., LTD. TOKYO, JAPAN
Hardness			Dimensions		
Plating			Angles		

This drawing is provisional and subject to our reconfirmation and/or revision without notice.

*** T I P W (01) *** (2100 1121) 03-06-02

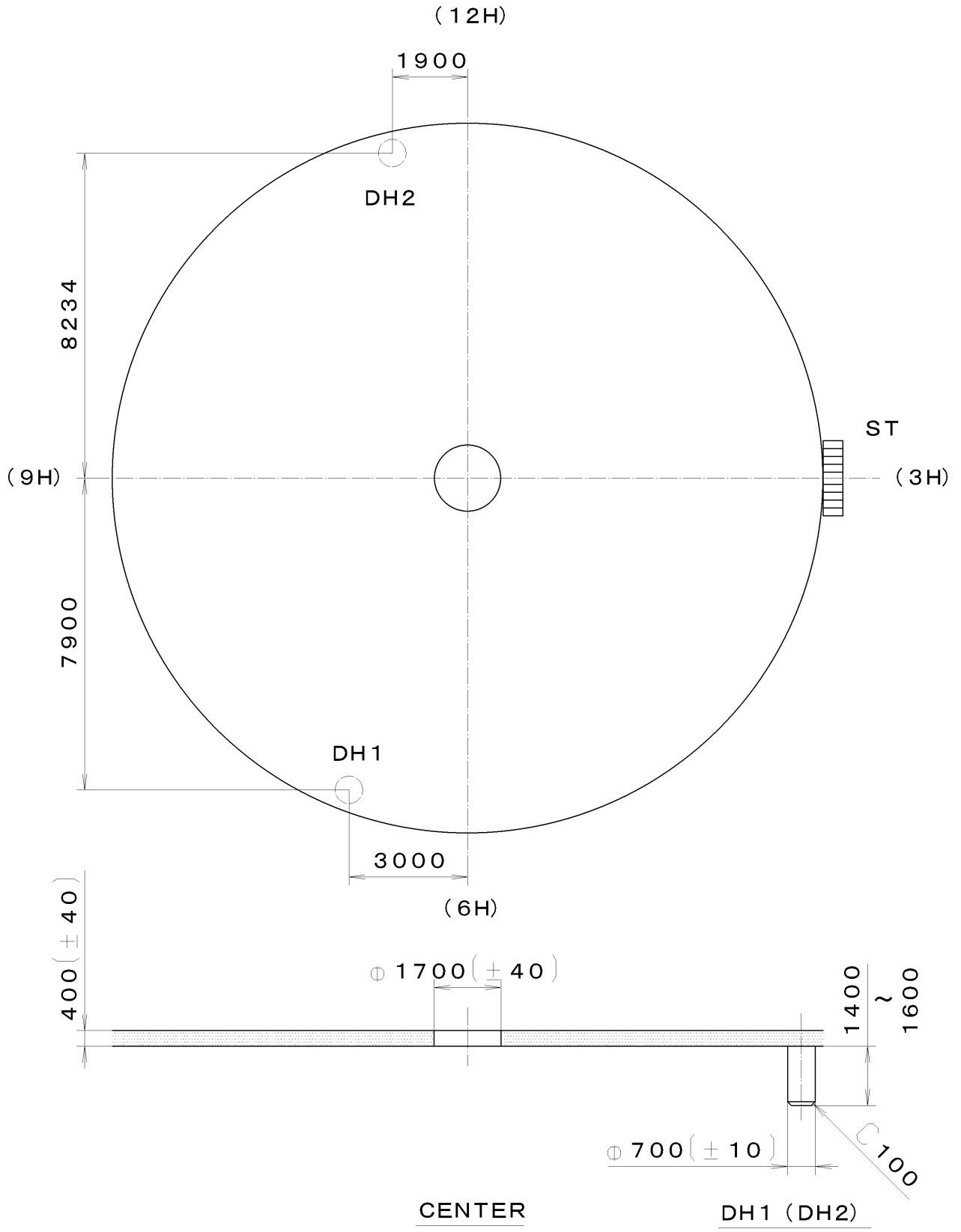

△7			Quantity		Cal. No. :	GL30-00A
△6			Unit	1/1000 mm		
△5			Scale	7:1	Parts:	Name: Indications for Dial
△4			Date			
△3			Drawn			
△2			Checked	M. Fukuda	Drawing No. : GL30D000	
△1			Approved			
Material			General Tolerances			CITIZEN WATCH CO., LTD. TOKYO, JAPAN
Heat Treatment			Dimensions			
Hardness			Angles			
Plating						

This drawing is provisional and subject to our reconfirmation and/or revision without notice.

*** T I P W (01) *** (2100 1121) 03-06-03

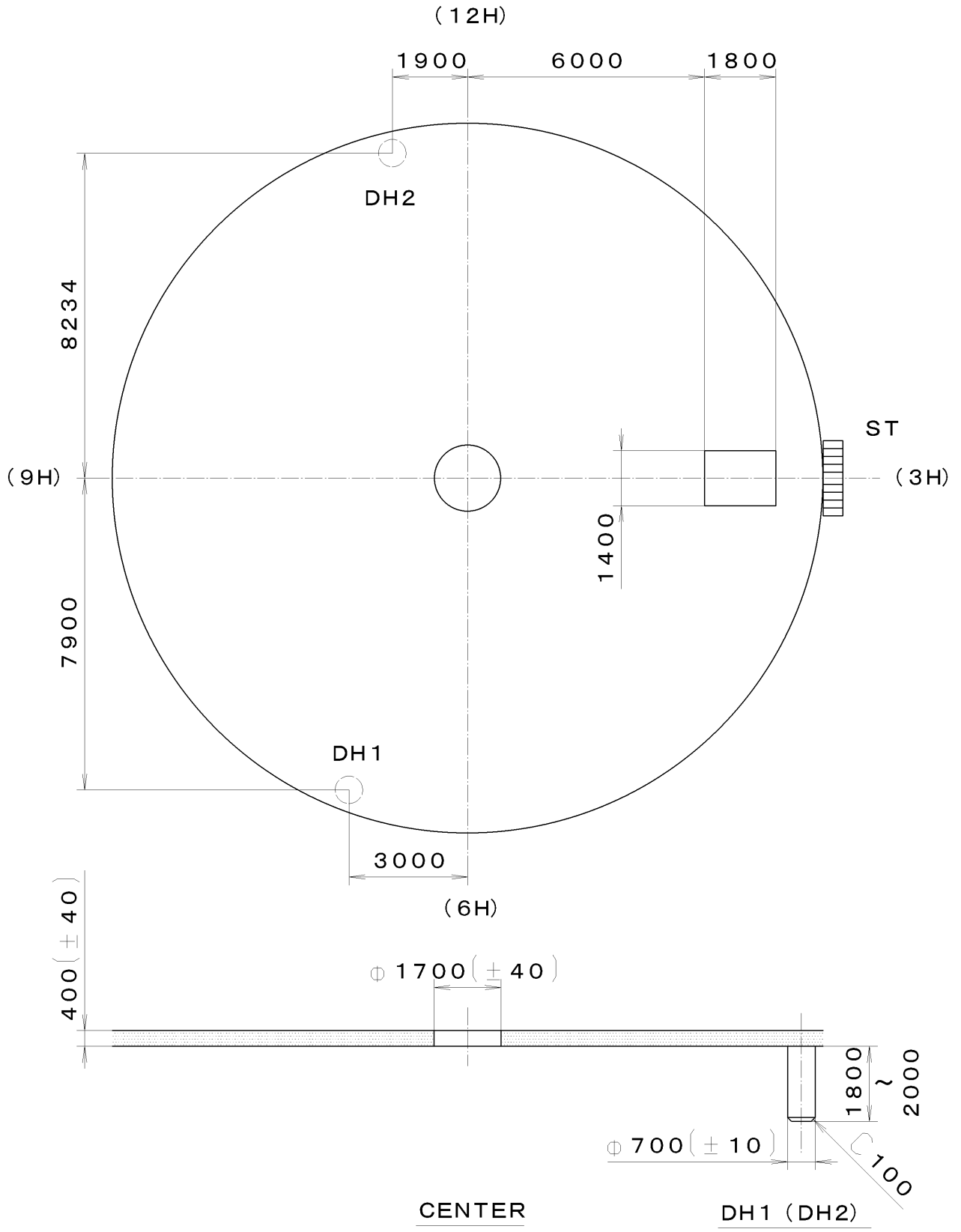

△7			Quantity		Cal. No. :	GL10-00A
△6			Unit	1/1000 mm	Parts:	
△5			Scale	7:1	Name:	Indications for Dial
△4			Date		Drawing No. :	
△3			Drawn		CITIZEN WATCH CO., LTD. TOKYO, JAPAN	
△2			Checked	M. Fukuda		
△1			Approved			
Material			General Tolerances			
Heat Treatment			Dimensions			
Hardness			Angles			
Plating						

This drawing is provisional and subject to our reconfirmation and/or revision without notice.

*** T I P W (01) *** (2100 1121) 03-06-03

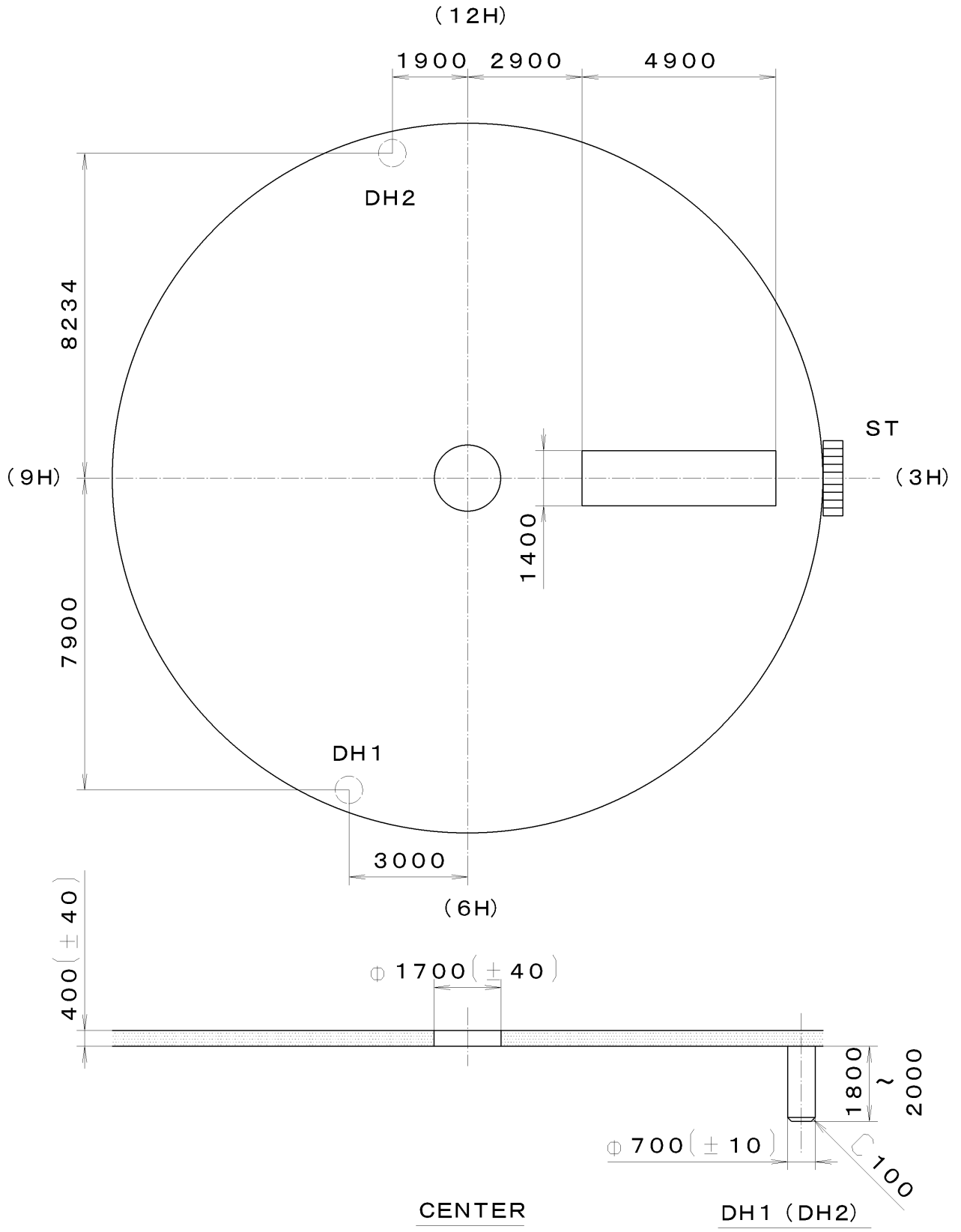

△7		Quantity		Cal. No. :	GL00-00A
△6		Unit	1/1000 mm		
△5		Scale	7:1	Parts:	
△4		Date			
△3		Drawn			
△2		Checked	M. Fukuda	Name:	Indications for Dial
△1		Approved		Drawing No. :	
Material					
Heat Treatment		General Tolerances		CITIZEN WATCH CO., LTD. TOKYO, JAPAN	
Hardness		Dimensions			
Plating		Angles			

This drawing is provisional and subject to our reconfirmation and/or revision without notice.

*** T I P W GM10-00A (01) *** (2100 1121) 03-06-02

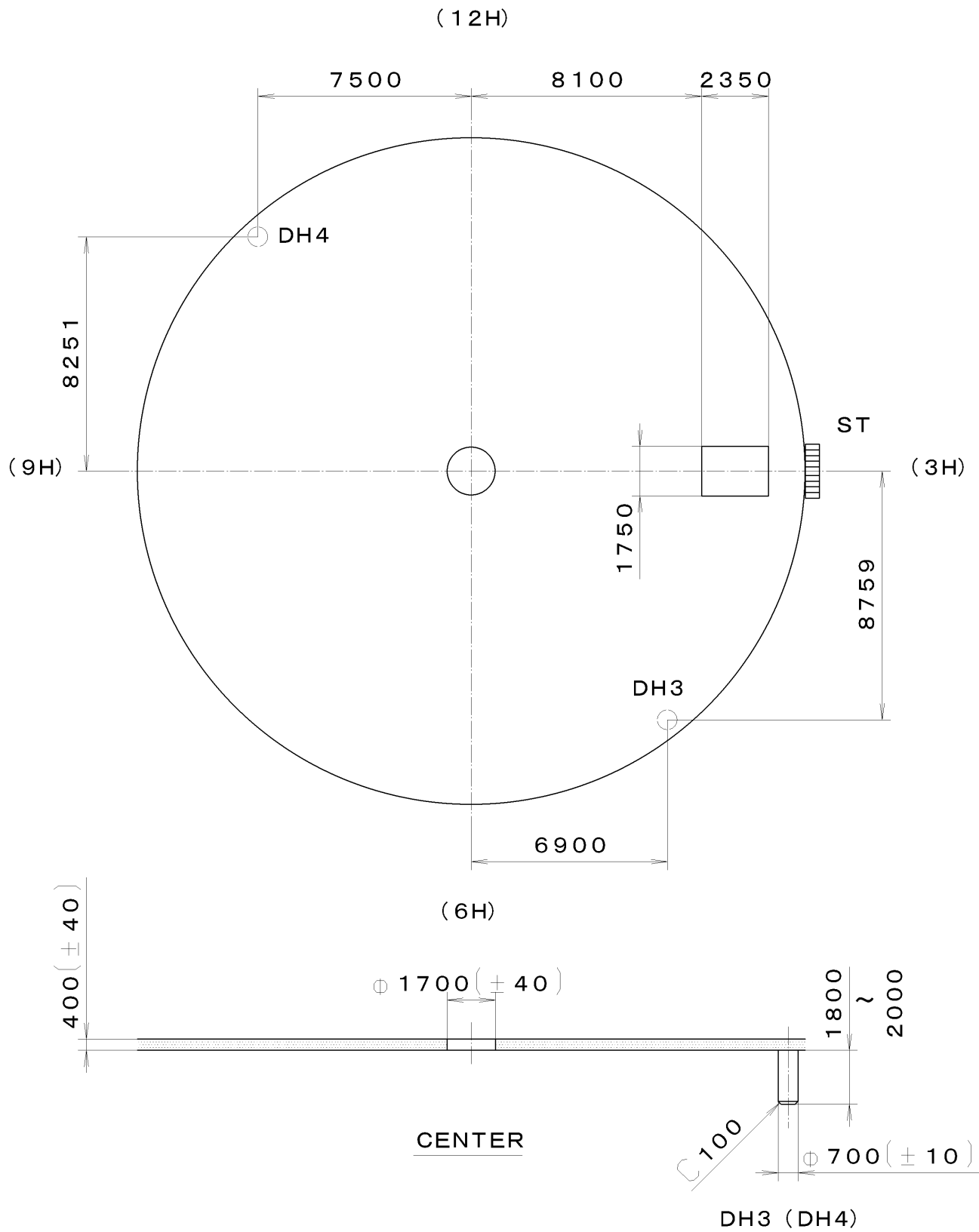

Quantity		Cal. No. : GM10-00A	
Unit 1/1000 mm		Parts:	
Scale 5:1			
Date		Name: Indiations for Dial	
Drawn			
Checked M. Fukuda		Drawing No. : GM10D000	
Approved			
Material	General Tolerances		CITIZEN WATCH CO., LTD. TOKYO, JAPAN
Heat Treatment	Dimensions		
Hardness	Angles		
Plating			

This drawing is provisional and subject to our reconfirmation and/or revision without notice.

*** T I P W GM00-00A (01) *** (2100 1121) 03-06-02

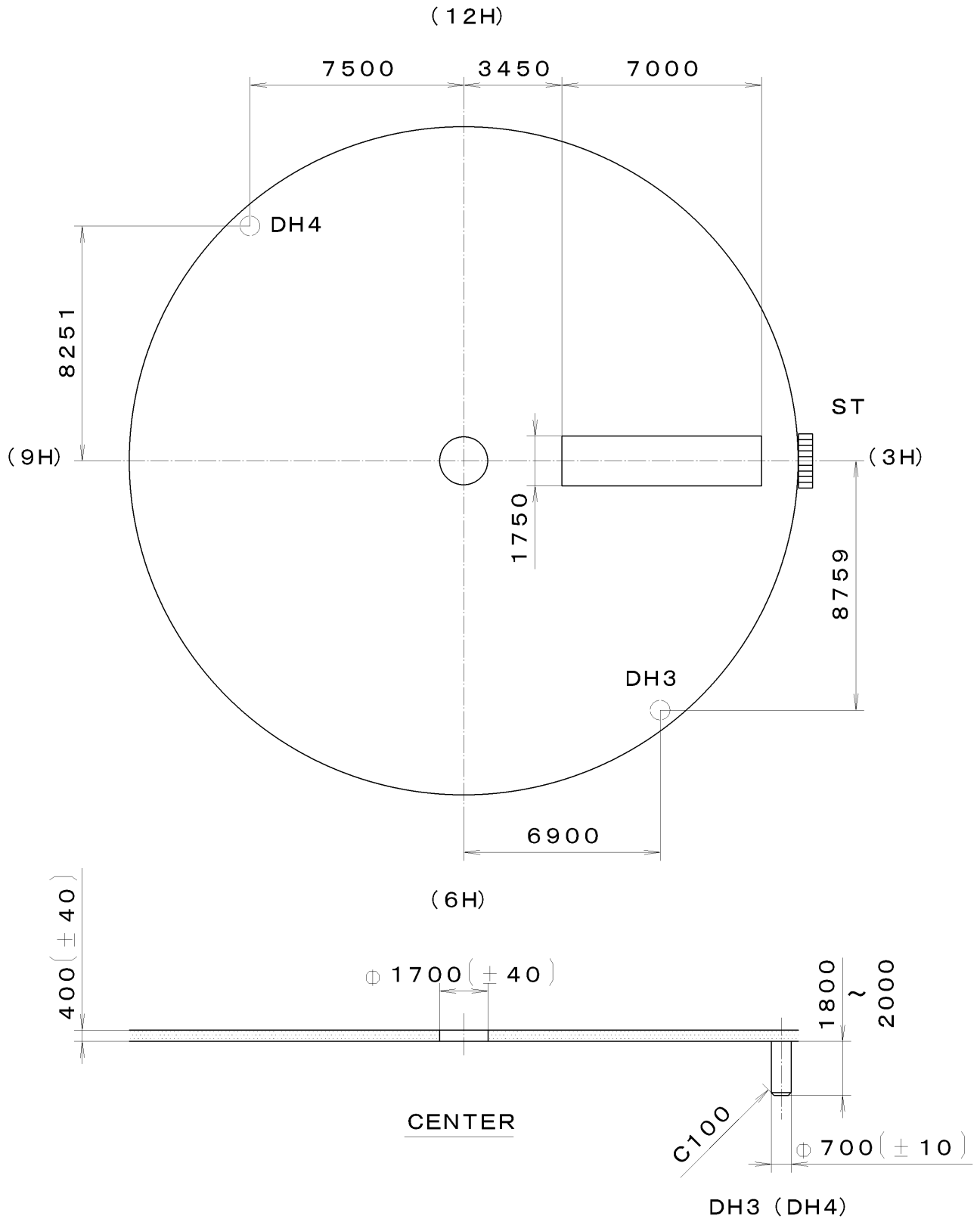

△7			Quantity		Cal. No. : GM00-00A
△6			Unit	1/1000 mm	Parts:
△5			Scale	5:1	
△4			Date		Name: Indications for Dial
△3			Drawn		
△2			Checked	M. Fukuda	Drawing No. : GM00D000
△1			Approved		
Material					
Heat Treatment			General Tolerances		
Hardness			Dimensions		
Plating			Angles		

CITIZEN WATCH CO., LTD.
TOKYO, JAPAN