

ETA 256.0x1 / 256.1x1





COMMUNICATION
TECHNIQUE

TECHNISCHE
MITTEILUNG

TECHNICAL
COMMUNICATION

8 1/4'''

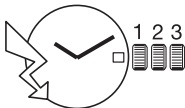
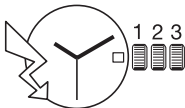
				
	LONG LIFE	E.O.L	LONG LIFE	E.O.L
Hauteur sur mouvement Höhe auf Werk Movement height	1,95 mm			
Hauteur sur pile Höhe auf Batterie Height on battery	2,10 mm			
8 1/4''' Ø 18,20 mm	256.031	256.101	256.041	256.111

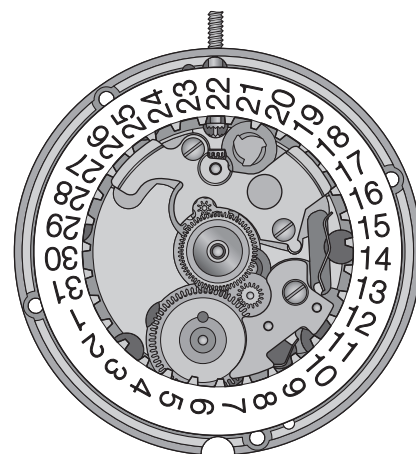

ETA SA
MANUFACTURE HORLOGÈRE SUISSE
DEPUIS 1793

Interchangeabilité - Auswechselbarkeit - Interchangeability





































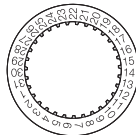



No Nr No	No Nr CS No	LISTE DES FOURNITURES	BESTANDTEIL- LISTE	LIST OF MATERIALS	Cal. - Kal. - Cal.			
					256.031	256.041	256.101	256.111
100	10.020.07	Platine, empierrée	Werkplatte, mit Steinen	Main plate, jewelled	256.031	256.041	256.101	256.111
110	10.048.07	Pont de rouage, empierré	Räderwerkbrücke, mit Steinen	Train wheel bridge, jewelled	256.041	256.041	256.111	256.111
144	10.300.00	Fixateur de cadran	Zifferblatthalter	Dial fastener	256.101	256.101	256.101	256.101
161	80.400.00	Tube de centre	Zentrumlagerrohr	Centre tube	256.111	256.111	256.111	256.111
203	30.012.00	Roue intermédiaire	Zwischenrad	Intermediate wheel	256.041	256.041	256.111	256.111
210	30.025.00	Roue moyenne	Kleinbodenrad	Third wheel	256.111	256.111	256.111	256.111
227	30.027.00	Roue de seconde	Sekundenrad	Second wheel	---	---	256.111	256.111
228	30.013.00	Roue de transmission de roue intermédiaire	Übertragungsrad für Zwischenrad	Transmission wheel for intermediate wheel	---	---	256.111	256.111
242	31.083.00	Chaussée avec entraîneur	Minutenrohr mit Mitnehmer	Cannon pinion with driver	---	---	256.111	256.111
242/1	31.083.18	Chaussée avec entraîneur, sans seconde au centre	Minutenrohr mit Mitnehmer, ohne Zentralsekunde	Cannon pinion with driver, without sweep second	256.041	256.041	---	---
255/1	31.046.06	Roue des heures, montée	Stundenrad, montiert	Hour wheel, assembled	256.041	256.041	256.111	256.111
260	31.041.00	Roue de minuterie	Wechselrad	Minute wheel	256.111	256.111	256.111	256.111
405	51.020.21	Tige de mise à l'heure, ø de filetage 0,90 mm	Stellwelle, Gewindedurchmesser 0,90 mm	Handsetting stem, thread diameter 0.90 mm	256.111	256.111	256.111	256.111
405/4	51.021.26	Tige de mise à l'heure, partie mouvement à bec	Stellwelle, Werkteil mit Zunge	Handsetting stem, movement part with beak	256.111	256.111	256.111	256.111
407	31.121.00	Pignon coulant	Kupplungstrieb	Sliding pinion	256.111	256.111	256.111	256.111
435/1	51.050.06	Bascule de pignon coulant, montée	Kupplungstriebhebel, montiert	Yoke, assembled	256.111	256.111	256.111	256.111
443/1	51.080.06	Tirette montée	Winkelhebel, montiert	Setting lever, assembled	256.111	256.111	256.111	256.111
445	51.090.00	Sautoir de tirette	Winkelhebelraste	Setting lever jumper	256.101	256.111	256.101	256.111
450	31.100.00	Renvoi	Zeigerstellrad	Setting wheel	256.111	256.111	256.111	256.111
462	10.062.00	Pont de rouage de minuterie	Wechselradbrücke	Minute train bridge	256.111	256.111	256.111	256.111
482	61.092.00	Ressort de rappel de tirette	Winkelhebelrückstellfeder	Setting lever recall spring	256.111	256.111	256.111	256.111
491	51.081.00	Levier de tirette	Hebel für Winkelhebel	Lever for setting lever	256.111	256.111	256.111	256.111
560	56.071.00	Levier d'arrêt et interrupteur	Stopphebel und Unterbrecher	Stop lever and switch	256.111	256.111	256.111	256.111
964	51.022.30	Tige de mise à l'heure, partie couronne, fendue ø de filetage 0,90 mm	Stellwelle-Kronenteil, geschlitzt, Gewinde-ø 0,90 mm	Handsetting stem, crown part, slotted, thread-ø 0,90 mm	256.111	256.111	256.111	256.111
2543	33.011.00	Roue intermédiaire de quantité	Datum-Zwischenrad	Intermediate date wheel	---	256.111	---	256.111
2556	33.020.00	Roue entraîneuse de l'indicateur de quantité	Datumanzeiger-Mitnehmerad	Date indicator driving wheel	---	256.111	---	256.111
2557/1	91.440.22	Indicateur de quantité, ouverture de guichet à 3 h	Datumanzeiger, für Fenster bei 3 Uhr	Date indicator, for opening at 3 o'clock	---	256.111	---	256.111
2576	53.080.00	Sautoir de quantité	Datumraste	Date jumper	256.111	256.111	256.111	256.111
2595	13.111.00	Plaque de maintien du sautoir de quantité	Halteplatte für Datumraste	Date jumper maintaining plate	256.111	256.111	256.111	256.111
4000	10.513.00	Module électronique	Elektronik-Baugruppe	Electronic module	256.041	256.041	256.111	256.111
4021	20.582.00	Stator	Stator	Stator	256.111	256.111	256.111	256.111
4039	20.585.00	Ecran magnétique, inférieur	Magnetschirm, unten	Magnetic screen, lower	256.101	---	256.101	---
4041	20.586.00	Ecran magnétique, latéral	Magnetschirm, seitlich	Magnetic screen, lateral	256.111	256.111	256.111	256.111
4046	20.651.00	Isolateur de pile, dessous	Isolation für Batterie	Battery insulator	256.101	256.101	256.101	256.101
4211	20.580.00	Rotor	Rotor	Rotor	256.111	256.111	256.111	256.111
4401	20.761.00	Bride +	Bügel +	Bridle +	256.111	256.111	256.111	256.111
4412	10.601.00	Ressort de limitation de pile	Begrenzungsfeder für Batterie	Battery limiting spring	956.401	956.401	956.401	956.401
4929	20.570.00	Pile	Batterie	Battery	256.111	256.111	256.111	256.111
5101	10.020.01	2x Vis de fixation	Schraube für Werkbefestigung	Screw for case	256.111	256.111	256.111	256.111
5102	10.020.02	2x Vis de fixation, spéciale	Schraube für Werkbefestigung, Spezial-Ausführung	Screw for case, special	256.111	256.111	256.111	256.111
1) 5110	10.048.01	2x Vis de pont de rouage	Schraube für Räderwerkbrücke	Screw for train wheel bridge	256.111	256.111	256.111	256.111
1) 5445	51.090.01	1x Vis du sautoir de tirette	Schraube für Winkelhebelraste	Screw for setting lever jumper	256.111	256.111	256.111	256.111
2) 5462	10.062.01	2x Vis de pont du rouage de minuterie	Schraube für Wechselradbrücke	Screw for minute train bridge	256.111	256.111	256.111	256.111
1) 5482	61.092.01	1x Vis de ressort de rappel de tirette	Schraube für Winkelhebelrückstellfeder	Screw for setting lever recall spring	256.111	256.111	256.111	256.111

Interchangeabilité - Auswechselbarkeit - Interchangeability

No Nr No	No Nr CS No	LISTE DES FOURNITURES	BESTANDTEIL- LISTE	LIST OF MATERIALS	Cal. - Kal. - Cal.					
					256.031	256.041	256.101	256.111		
2)	52595	13.111.01	1x	Vis de plaque de maintien du sautoir de quantième	Schraube für Halteplatte für Datumraste	Screw for date jumper maintaining plate	256.111	256.111	256.111	256.111
	54000	10.513.01	4x	Vis de module électronique	Schraube für Elektronik-Baugruppe	Screw for electronic module	256.111	256.111	256.111	256.111
1)	54041	20.761.01	1x	Vis d'écran magnétique, latéral	Schraube für seitlichen Magnetschirm	Screw for lateral magnetic screen	256.111	256.111	256.111	256.111
1)	54041	20.761.01	1x	Vis de bride +	Schraube für Bügel +	Screw for bridle +	256.111	256.111	256.111	256.111
1) 2) Vis identiques Identische Schrauben Identical screws					1) 5110 5445 5482 54041 54401	2) 5462 52595				

Vis Schrauben Screws	M _L Couple minimum pour dévisser M _L Minimales Drehmoment zum Lösen M _L Minimum torque for loosening
5101 5102	1,0 Ncm

Fournitures - Bestandteile - Materials

											5101
100	110	144	161	203	210	227	228	242			
											5102
255/1	260	405	407	435/1	443/1	445	450	462			
										5110 5445 5482 54041 54401	
482	491	560	2543	2556	2557/1		2576	2595			
										5462 52595	
4000	4021	4041	4046	4211	4401	4412	4929	54000			

Montage du mécanisme de calendrier.

(Liste des fournitures par ordre d'assemblage)

Zusammenstellen des Kalender-Mechanismus.

(Bestandteilliste in Montagerihenfolge)

Assembling of the calendar mechanism.

(Parts listed in order of assembly)

100	450	462
242	2576	5462 (2x)
2556	2595	255/1
2543	52595	
260	2557/1	

Lubrification – Schmierung – Lubrication

 Huile fine **Moebius 9014**
 Dünnflüssiges Öl ou / oder / or
 Fine oil **Moebius 9034**

 Huile épaisse à viscosité élevée ou graisse **Moebius D5**
 Dickflüssiges druckfestes Öl oder Fett ou / oder / or **HP-1300**
 Thick, pressure-resistant oil or grease

 Graisse **Moebius 9501**
 Fett ou / oder / or **Jismaa 124**
 Grease

 Très faible lubrification **Moebius D5**
 Sehr kleine Menge ou / oder / or **HP-1300**
 Very small lubrication

M_L Couple minimum pour dévisser
M_L Minimales Drehmoment zum Lösen
M_L Minimum torque for loosening

(a) 0,6 Ncm

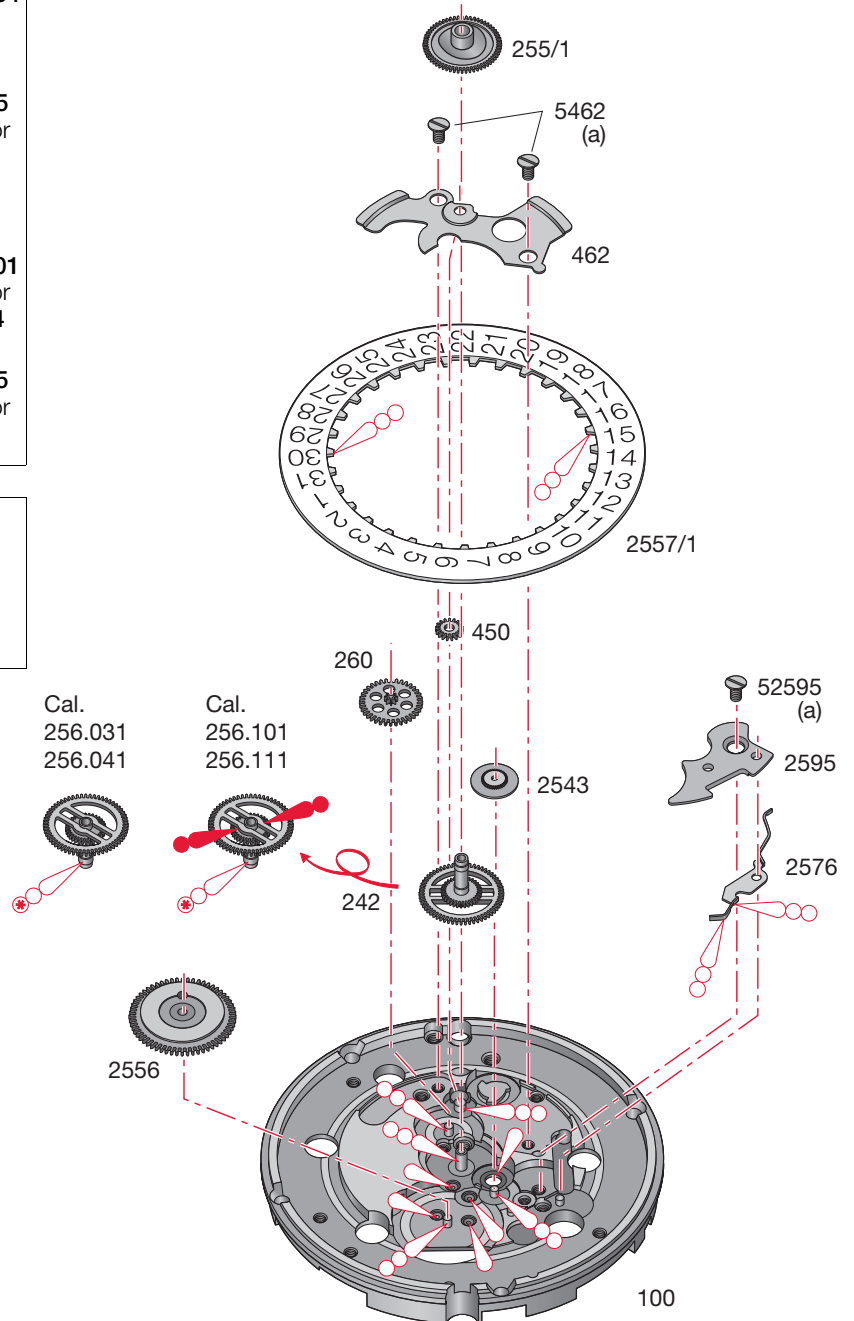

Montage du mécanisme de quantième et correcteur

(Liste des fournitures par ordre d'assemblage)

Zusammenstellen des Datum- und Korrektormechanismus

(Bestandteilliste in Montagereihenfolge)

Assembling of the date and corrector mechanism

(Parts listed in order of assembly)

100	482	5110 (2x)
407	5482	4041
405	4021	54041
491	4211	4401
443/1	210	54401
560	227	4046
435/1	228	4000
445	203	54000 (3x)
5445	110	4929

M_L Couple minimum pour dévisser

M_L Minimales Drehmoment zum Lösen

M_L Minimum torque for loosening

(b) 0,7 Ncm

Lubrification – Schmierung – Lubrication

Huile fine
 Düninflüssiges Öl
 Fine oil

Moebius 9014
 ou / oder / or
Moebius 9034

Huile épaisse à viscosité élevée ou graisse
 Dickflüssiges druckfestes Öl oder Fett
 Thick, pressure-resistant oil or grease

Moebius D5
 ou / oder / or
HP-1300

Graisse
 Fett
 Grease

Moebius 9501
 ou / oder / or
Jismaa 124

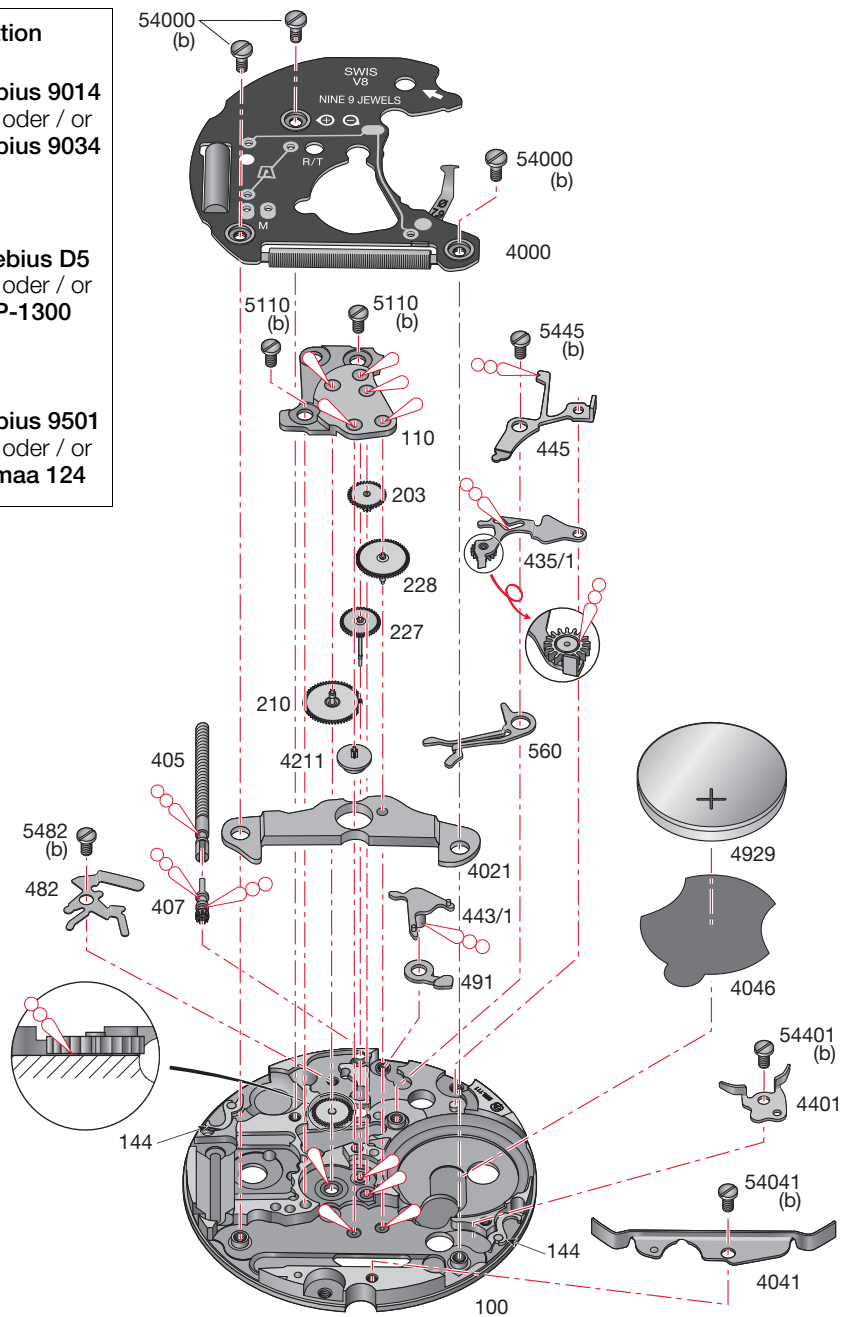

Contrôles électriques - Elektrische Kontrollen - Electrical tests

Position Messpunkt Position	Echelle de mesure Einstellung Messgerät Setting of apparatus	Mesure Messung Measurement	Contrôle Kontrolle Test	Remarques Bemerkungen Remarks	
1	2 V (Ri ≥ 10 kΩ/V)	1,55 V	Tension de la pile Spannung der Batterie Battery voltage	Mesure avec pile Messung mit Batterie Measurement with battery	
2	1 V (Ri ≥ 10 kΩ/V)	L'aiguille du multimètre oscille en sens + et - . Zeiger im Messgerät pulsiert im + und - Sinn. Hand of measuring apparatus oscillates in + and - direction.	Impulsion à la sortie du circuit intégré. Ausgangsimpulse am integrierten Schaltkreis. Impulses at output of integrated circuit. 256.031 256.101 256.041 256.111 12 / min 1 / s	Mesure avec une pile contrôlée Messung mit kontrollierter Batterie Measurement with controlled battery	
3	2 V	≤ 1,30 V 256.031 / 256.041 256.101 / 256.111 Mettre en contact le point R/T et la piste - . Commande du moteur avec 32 pas/s ou 16 pas/s. R/T Punkt mit der - Spur verbinden. Motorantrieb mit 32 Schritten/s oder 16 Schritten/s. Connect R/T point with the - conductor. Motor driven with 32 steps/s or 16 steps/s.	Mettre en contact le point R/T et la piste - . Commande du moteur avec 8 pas/s à 1,55 V et 32 pas/s avec tension ≤ 1,30 V (E.O.L). R/T Punkt mit der - Spur verbinden. Motorantrieb mit 8 Schritten/s bei 1,55V und 32 Schritten/s mit Spannung ≤ 1,30 V (E.O.L). Connect R/T point with the - conductor. Motor driven with 8 steps/s at 1,55 V and 32 steps/s with voltage ≤ 1,30 V (E.O.L).	Limite inférieure de la tension de fonctionnement. Untere Funktionsspannungsgrenze. Lower working voltage limit.	Mesure sans pile, alimentation extérieure variable, en descendant de 1,55 V à l'arrêt du mouvement. Messung ohne Batterie, mit variabler Speisung von aussen, Spannung von 1,55 V reduzieren bis zum Stillstand des Werkes. Measurement without battery, with variable external power supply, starting with 1.55 V, lower tension until movement stops.
	10 μA	≤ 0,75 μA	≤ 1,20 μA	Consommation du mouvement Stromaufnahme Uhrwerk Power consumption of movement	Mesure sans pile, avec alimentation extérieure 1,55 V. Messung ohne Batterie, mit Speisegerät 1,55 V. Measurement without battery, with power-supply unit 1.55 V.
	< 0,40 μA	< 0,40 μA	Saut de 4 pas toutes les 4 secondes lorsque la tension d'alimentation < 1,30 V. 4-Schritte-Sprung alle 4 Sekunden, wenn Speisespannung < 1,30 V. 4-steps jump after every 4 seconds, when feeding voltage < 1.30 V.	EOL. Consommation supérieure à la valeur normale. EOL. Stromaufnahme über dem Normalwert. EOL. Consumption higher than in normal operation.	Mesure sans pile, avec tension d'alimentation < 1,30 V, EOL-Fonction après ~ 2 minutes. Messung ohne Batterie, mit Speisespannung < 1,30 V, EOL-Funktion nach ~ 2 Minuten. Measurement without battery, with supply voltage < 1.40 V, EOL-Function after about 2 minutes.
4	• 10 kΩ 200 μA	1,30 - 1,60 kΩ 125 - 155 μA	1,30 - 1,80 kΩ 110 - 155 μA	Continuité du bobinage Zustand der Spule Condition of coil	
<i>Ohmmètres avec tension de mesure supérieure à 0,40 V inappropriés, tension recommandée 0,20 V.</i> • <i>Ohmmeter mit Prüfspannung über 0,40 V ungeeignet, empfohlene Spannung 0,20 V.</i> <i>Ohmmeter with a test voltage exceeding 0.40 V unsuitable, recommended voltage 0.20 V.</i>			<i>Température ambiante 20°C.</i> <i>Raumtemperatur 20°C.</i> <i>Ambient temperature 20°C.</i>		

Contrôles électriques - Elektrische Kontrollen - Electrical tests

256.031 / 256.041

256.101 / 256.111

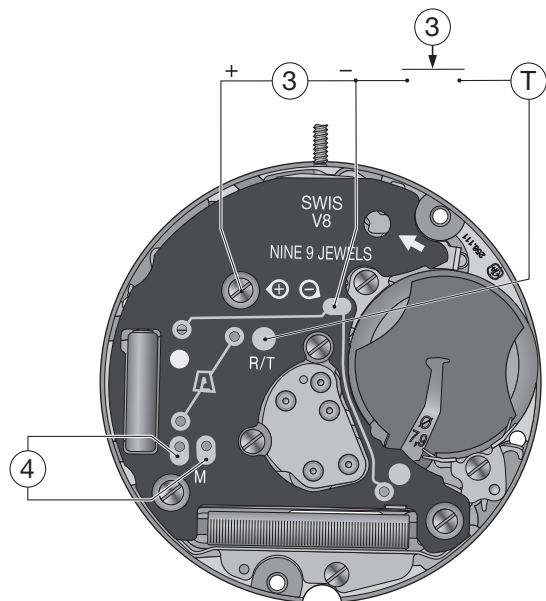
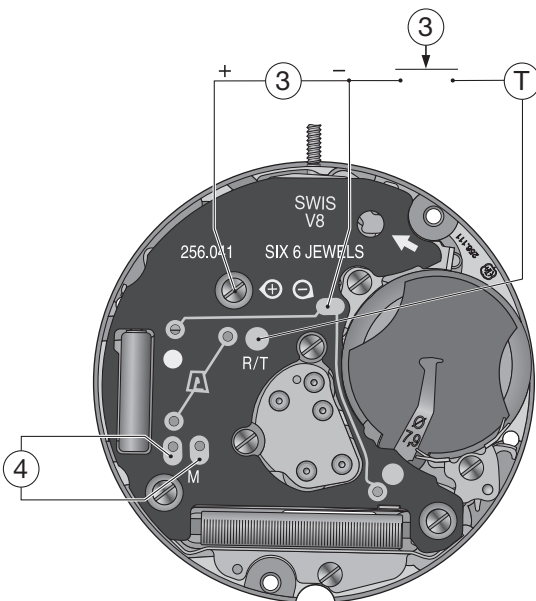
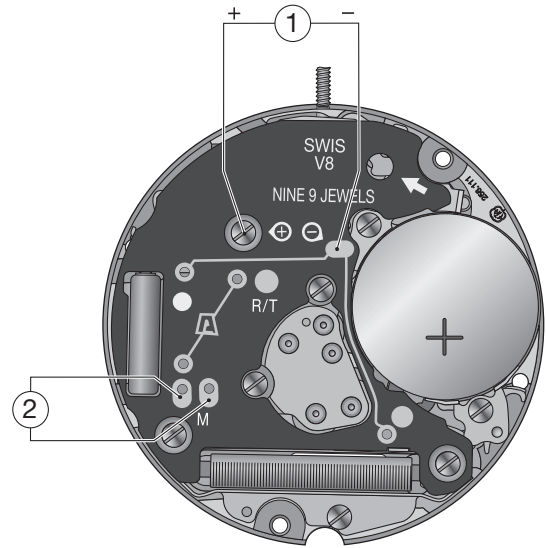
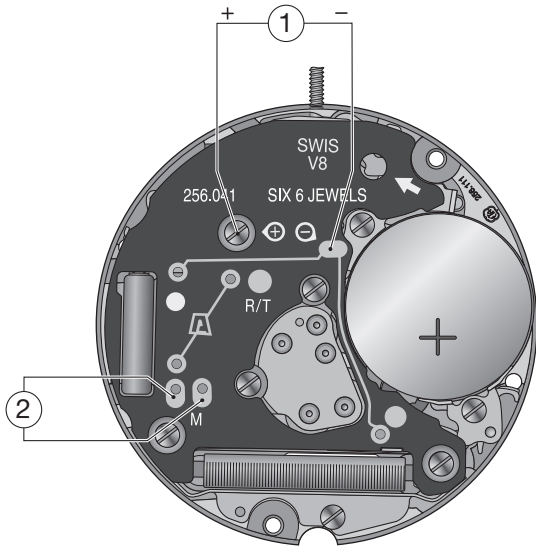

Extraction de la tige de mise à l'heure

Enlever la tige de mise à l'heure en pressant le levier de tirette, indiqué par une flèche, avec un tournevis de \varnothing 1 mm.

Entfernen der Stellwelle

Lösen der Stellwelle durch Druck auf den Hebel für Winkelhebel, angezeigt durch einen Pfeil, mit einem Schraubenzieher \varnothing 1 mm.

Extracting the stem

To extract the stem, press the lever for setting-lever, shown by an arrow, with a screwdriver 1 mm in diameter.

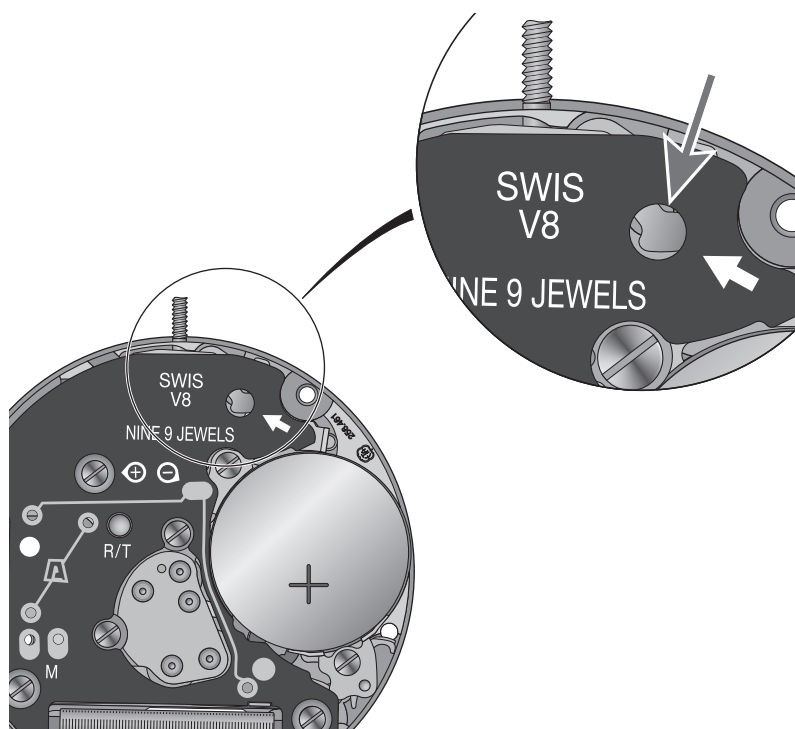

Pose du caran et des aiguilles

Poser le cadran en pressant simultanément au moyen d'un cabron de peau à l'endroit des 2 pieds, ceux-ci étant maintenus avec 2 fixateurs de cadran.

Zifferblatt- und Zeigersetzen

Zifferblattsetzen durch gleichzeitigen Druck mit einer Lederfeile auf das Zifferblatt über den beiden Zifferblattfüßen. Das Zifferblatt wird von 2 Zifferblatthaltern festgehalten.

Fitting dial and hands

Fit dial by pressing simultaneously, with a leather buff on both dial feet. The dial is held by two dial fasteners.

Remarque:

- Contrôler l'ébat de la roue des heures, de 0.02 à 0.06 mm.
- Contrôler la liberté du disque de quantième sous le cadran, en correction rapide.
- Tourner la tige de mise à l'heure jusqu'au moment du saut de quantième.
- Poser les aiguillages sur minuit. La pression de chassage ne doit pas être supérieure à 30N (~ 3kp). Nous recommandons l'utilisation de broches à forces compensées (3 kp max.).
- Utiliser un porte-pièce muni d'un appui central sur la pierre avec dégagement pour le pivot de seconde.
- Contrôler le repère des aiguillages.

Anmerkung:

- Kontrolle des Höhenspiels des Stundenrades: 0.02 bis 0.06 mm.
- Kontrolle des freien Spiels der Datumscheibe bei Schnellkorrektur.
- Stellwelle drehen bis zum Sprung der Datumscheibe.
- Zeiger auf Mitternacht setzen. Der Anpressdruck darf 30N (~ 3kp) nicht überschreiten. Wir empfehlen die Verwendung von druckkompensierten Broschen (3 kp max.).
- Werkträger mit zentraler Auflage für den Stein und Aussparung für den Zapfen des Sekundenrades verwenden.
- Bezugspunkt der Zeiger kontrollieren.

Note:

- Endshake of hour wheel: 0.02 to 0.06 mm.
- Check the free play of the date indicator in the quick correction mode.
- Turn handsetting stem till the date indication jumps.
- Fit the hands at 12 PM (midnight). The press-in force used for fitting the hands may not exceed 30N (~ 3kp.). We recommend the use of force compensated broaches (max. 3kp.).
- Use movement holder with central support for the jewel and having a hole for the centre pivot.
- Check the relative position of the hands.

Cadran

Pour ouvrir les deux fixateurs de cadran, presser en direction de la flèche A, jusqu'à ce que le trou de pied de cadran soit libre. Pour fermer les verrous après la pose du cadran, presser en direction de la flèche B, jusqu'au diamètre d'encageage de la platine. Pour enlever le cadran, tirer le bec C en direction de D.

Zifferblatt

Das Öffnen der zwei Zifferblatthalter geschieht durch Druck in Pfeilrichtung A, bis das Loch zur Aufnahme des Zifferblatffusses frei ist. Das Schliessen hat in Pfeilrichtung B zu erfolgen, bis zum Anschlag am Werkplattendurchmesser. Ein allfälliges Wiederöffnen der Riegel geschieht durch Ziehen der Nase C in Pfeilrichtung D.

Dial

To open the two dial fasteners, press in the direction of arrow A, so as to free the dial-foot hole. To close the bolts after the dial has been fitted, press in the direction of arrow B, as far as the case-fitting diameter of the main plate. To remove the dial, pull beak C towards D.

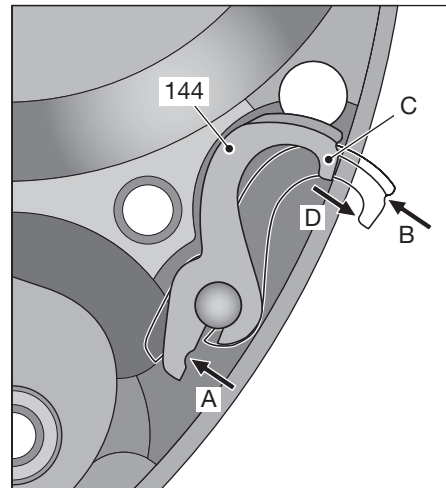

We reserve all rights for this document. It is meant for the recipient only and it may not be copied, printed or given to a third person without our written permission.

Für dieses Dokument behalten wir uns alle Rechte vor. Es ist nur für den Empfänger bestimmt. Ohne unsere schriftliche Bewilligung darf es nicht kopiert, vervielfältigt und Dritten zugänglich gemacht werden.

Nous nous réservons tous les droits sur ce document. Il est confié au destinataire. Il ne peut, sans notre autorisation écrite, être copié, reproduit, communiqué à des tiers.

Ajustement aiguille des heures
Stundenzeigerpassung
Hour hand fitting

Ajustement aiguille des minutes
Minutenzeigerpassung
Minute hand fitting

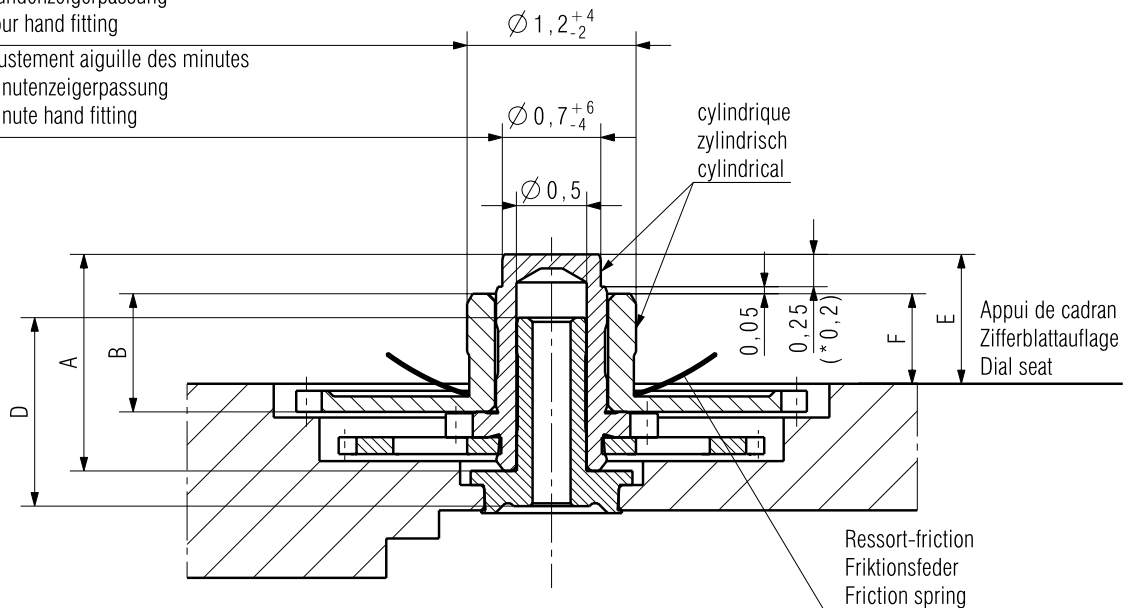

** Livraison contre supplément de prix
Lieferung gegen Aufpreis
Delivery with surcharge

Délais sur demande
Lieferfrist auf Anfrage
Delivery schedul on demand

Commercialisation sous réserve
Vertrieb mit Vorbehalt
Market launch with specific conditions

Aiguillage Zeigerwerkhöhe Hand fitting height	Longueur/Länge/Length			Dépassement Höhe über Zifferblattauflage Height over dial seat			Ep.cadran Zifferblattdicke Dial thickness
	A	B	D	E	F		
réduit* niedrig* reduced* normal	1,51	0,84	1,34	0,9	0,65		0,3
1	1,76	1,04	1,34	1,15	0,85		0,4
2**	2,01	1,29	1,34	1,4	1,1		0,4 - 0,7
3**	2,26	1,54	1,34	1,65	1,35		0,4 - 0,95
Aiguilles Zeiger Hands					Aiguille d'heure Stundenzeiger Hour hand		Aiguille de minute Minutenzeiger Minute hand
Masse/Masse/Mass					max.	mg	10
Balour/Unwucht/Unbalance					max.	µNm	3
Kaliber / Calibre / Caliber 256.031 / 256.041					Massestab Echelle Scale --		CATIA V5 Masse in mm Dimensions en mm Dimensions in mm Tot.1/1000 mm
AIGUILLAGES ZEIGERWERKHÖHEN HAND FITTING HEIGHTS					Z0091683		Version 01 00 Blatt Feuille Sheet 01/01
ETA SA MANUFACTURE HORLOGÈRE SUISSE DEPUIS 1793 A COMPANY OF THE			Ersatz für/En remplacement de/Remplacement for Aenderung/Modification 22226		Klass. Class. ZVACC		KUN
			Erstellt Etabri Created 19.04.2007 SCA		Geprüft Contrôle Controlled 19.04.2007 CHI		Freigegeben Libéré Released 20.04.2007 FEU

Ajustement aiguille des heures
Stundenzeigerpassung
Hour hand fitting

Ajustement aiguille des minutes
Minutenzeigerpassung
Minute hand fitting

Ajustement aiguille des secondes
Sekundenzeigerpassung
Second hand fitting

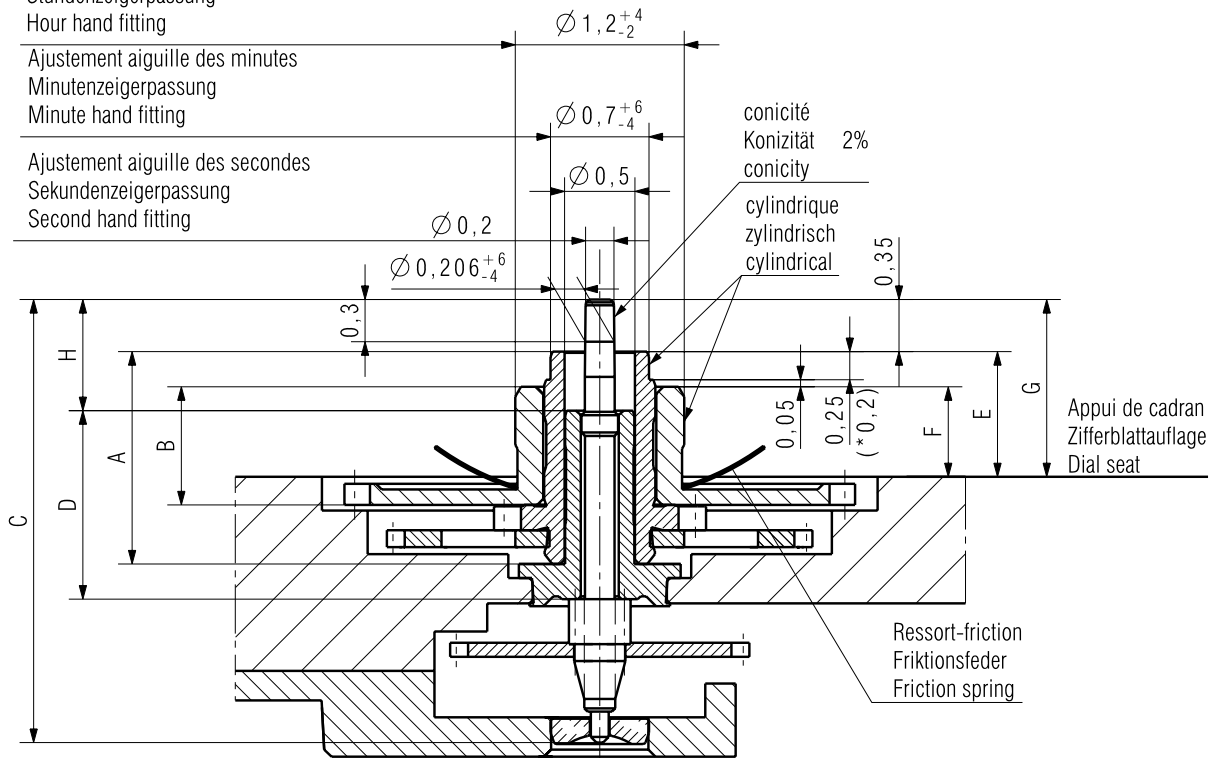

** Livraison contre supplément de prix
Lieferung gegen Aufpreis
Delivery with surcharge

Délais sur demande
Lieferfrist auf Anfrage
Delivery schedul on demand

Commercialisation sous réserve
Vertrieb mit Vorbehalt
Market launch with specific conditions

Aiguillage Zeigerwerkhöhe Hand fitting height	Longueur/Länge/Length				Dépassement Höhe über Zifferblattauflage Height over dial seat			H	Ep.cadran Zifferblattstärke Dial thickness
	A	B	C	D	E	F	G		
réduit* niedrig* reduced* normal	1,51	0,84	3,15	1,34	0,9	0,65	1,25	0,78	0,3
1	1,76	1,04	3,4	1,34	1,15	0,85	1,5	1,03	
3**	2,26	1,54	3,9	1,34	1,65	1,35	2	1,53	

Aiguilles Zeiger Hands		Aiguille d'heure Stundenzeiger Hour hand	Aiguille de minute Minutenzeiger Minute hand	Aiguille de seconde Sekundenzeiger Second hand
Masse/Masse/Mass	max.	mg		10
Balourd/Unwucht/Unbalance	max.	µNm		0,04

Kaliber / Calibre / Caliber	256.101 / 256.111 / 256.513	Masstab Echelle Scale		CATIA V5
		--	Masse in mm Dimensions en mm Dimensions in mm	Tol.1/1000 mm

AIGUILLAGES ZEIGERWERKHÖHEN HAND FITTING HEIGHTS	Z0091684	Version 01	Revision Révision 00	Blatt Feuille Sheet 01/01
--	----------	---------------	----------------------------	------------------------------------

ETA SA MANUFACTURE HORLOGÈRE SUISSE DEPUIS 1793 A COMPANY OF THE SWATCH GROUP	Ersatz für/En remplacement de/Remplacement for	Klass. Class.	ZVACC	KUN
	Aenderung/Modification	Erstellt Etabli Created	Geprüft Contrôlé Controlled	Freigegeben Libéré Released
	22226	19.04.2007 SCA	19.04.2007 CHI	20.04.2007 FEU

Nous nous réservons tous les droits sur ce document. Il est confié au destinataire. Il ne peut, sans notre autorisation écrite, être copié, reproduit, communiqué à des tiers.

Für dieses Dokument behalten wir uns alle Rechte vor. Es ist nur für den Empfänger bestimmt. Ohne unsere schriftliche Bewilligung darf es nicht kopiert, vervielfältigt und Dritten zugänglich gemacht werden.

We reserve all rights for this document. It is meant for the recipient only and it may not be copied, printed or given to a third person without our written permission.

Cette page est laissée blanche intentionnellement.

Diese Seite wird absichtlich weiss gelassen.

This page was left blank intentionally.

Cette page est laissée blanche intentionnellement.

Diese Seite wird absichtlich weiss gelassen.

This page was left blank intentionally.

Cette page est laissée blanche intentionnellement.

Diese Seite wird absichtlich weiss gelassen.

This page was left blank intentionally.

*Modifications comparées aux
versions précédentes du document*

*Änderungen gegenüber vorher-
gehenden Dokumentenversionen*

*Modifications compared with
previous document versions*

Version	Date Datum Date	Modification	Änderung	Modification	Page Seite Page
02	11.10.07	Nouveaux plans.	Neue Zeichnungen.	New drawings.	11, 12
		Couple minimum pour dévisser.	Minimales Drehmoment zum Lösen.	Minimum torque for loosening.	3, 5, 6
		Nouveaux fournitures.	Neue Bestandteile.	New materials.	4
		Nouveaux logos.	Neue Logos.	New logos.	1, 16
01	29.08.87	Version de base.	Basis Version.	Basic version.	--



ETA^{SA}
MANUFACTURE HORLOGÈRE SUISSE
DEPUIS 1793

CUSTOMER SERVICE

Bahnhofstrasse 9
P.O. Box 359
2540 Grenchen
Schweiz

Tel +41 (0)32 655 27 77
Fax +41 (0)32 655 84 30

etacs@eta.ch
www.eta.ch