

DH3~DH4=22287 (±20)

Coordinates

Mark	X	Y	R
GM	0	0	—
DH3	-8759	6900	—
DH4	8251	-7500	—
b1	8032	7877	500
b2	8624	7608	150
b3	10099	5501	150
b4	10149	4853	500
b5	7809	-8098	500
b6	7555	-8688	150
b7	5416	-10145	150
b8	4768	-10190	500
b9	-8032	-7877	500
b10	-8624	-7608	150
b11	-10099	-5501	150
b12	-10149	-4853	500
b13	-7809	8098	500
b14	-7555	8688	150
b15	-5416	10145	150
b16	-4767	10190	500

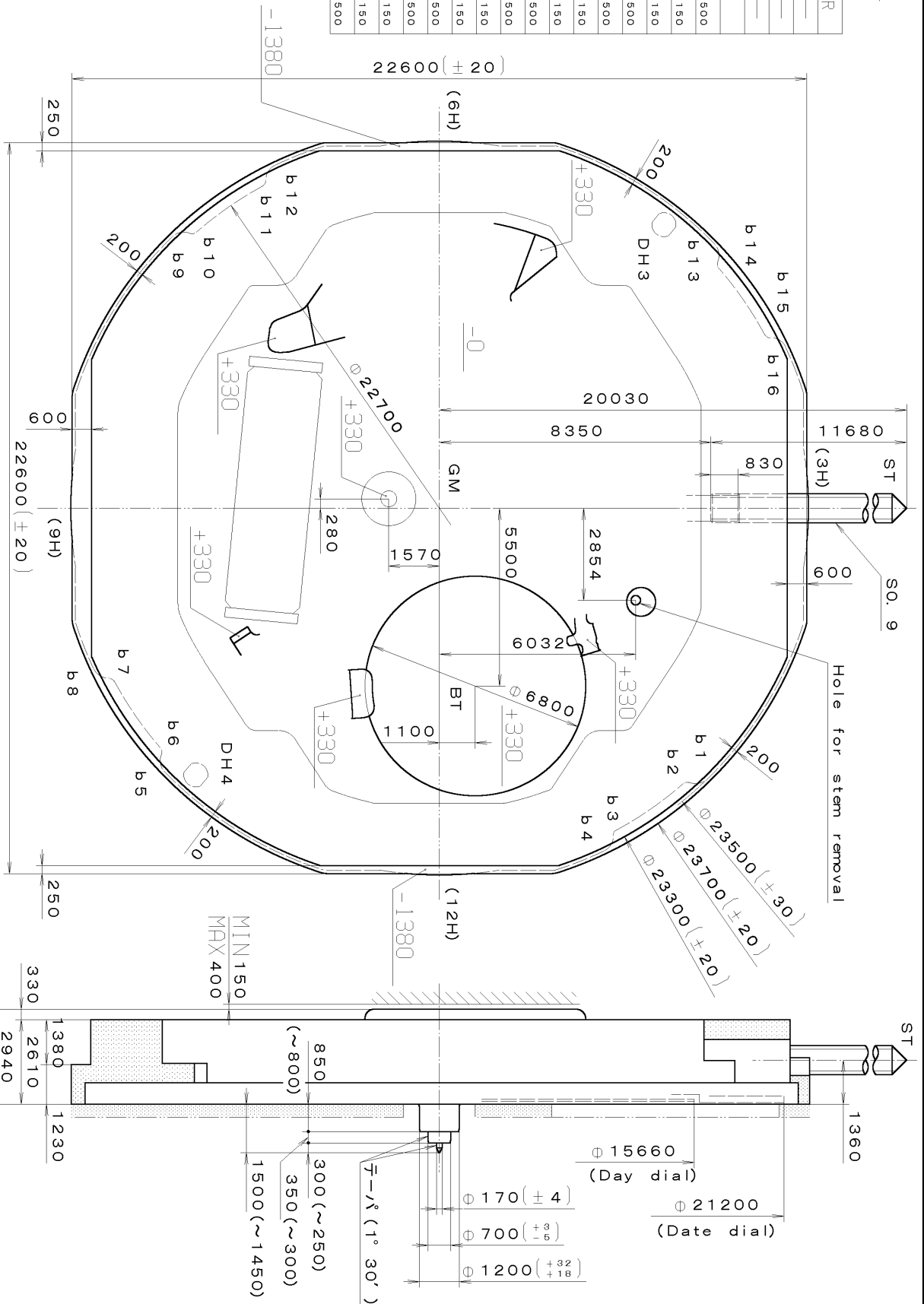

Section b1~b16

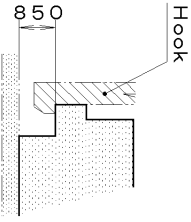

Material	Quantity	Unit	Cal. No. :
Material		1/1000 mm	1M02
Heat Treatment		Scale	Parts :
Hardness		8:1	
Plating		Date	
		Drawn	
		Checked	T. Hiruta
		Approved	
		Name :	Frame for Case
		Drawing No. :	1M02C0000
		General Tolerances	
		Dimensions	
		Angles	

CITIZEN WATCH CO., LTD.
TOKYO, JAPAN

This drawing is provisional and subject to our reconfirmation and/or revision without notice.

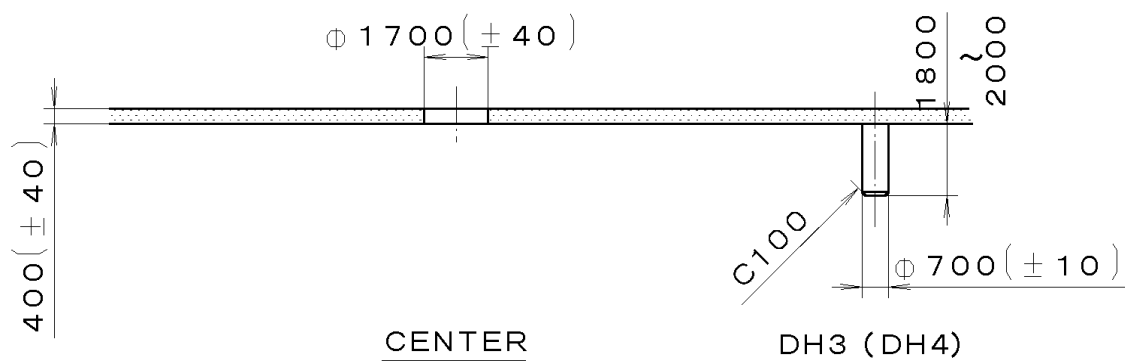
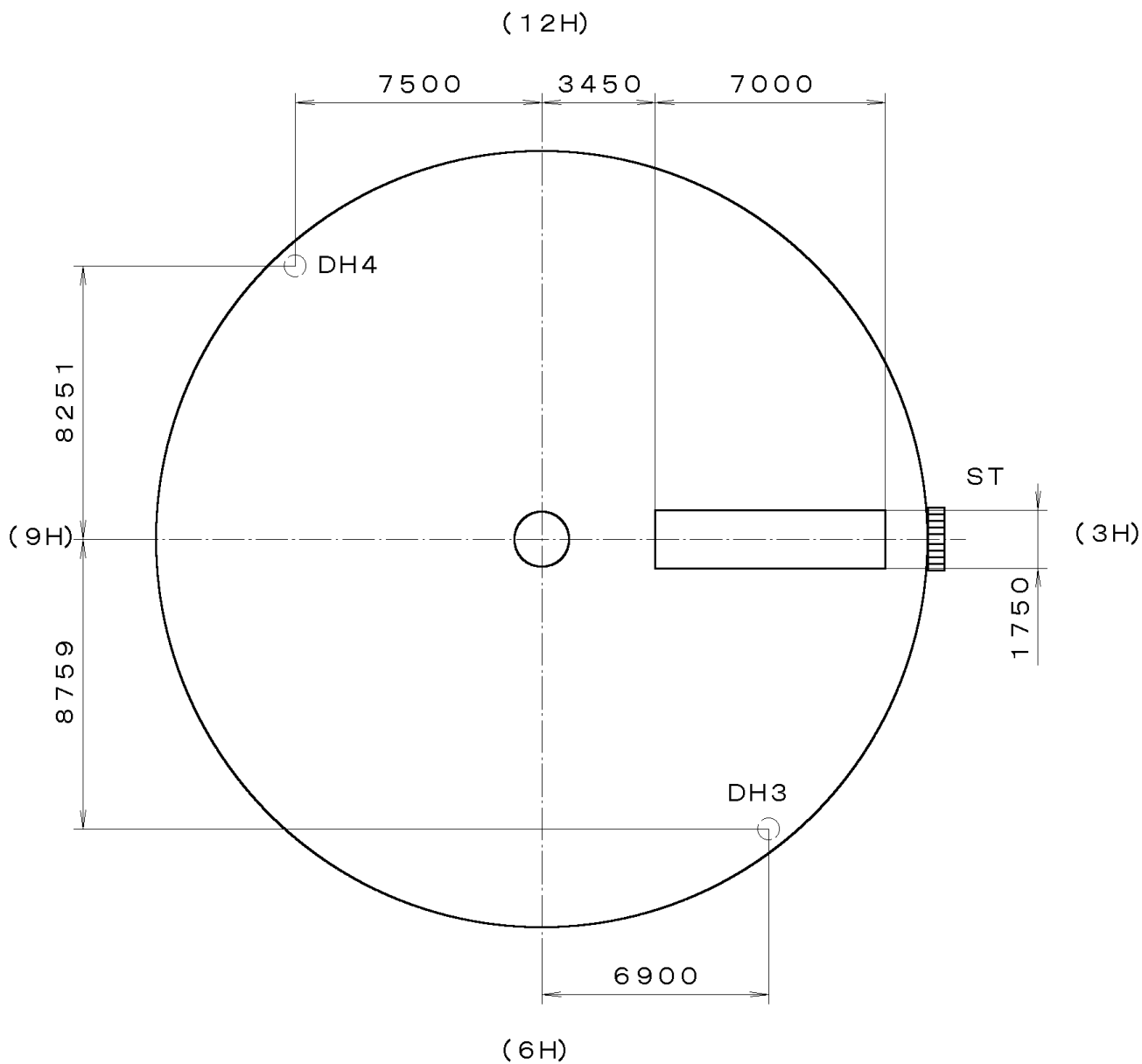

1M02-10A (01) *** (2100 1121) 00-06-28
 *** T I P W

7			Quantity		Cal. No. :	1M02-10A
6			Unit	1/1000 mm	Parts:	
5			Scale	5:1	Name:	Indications for Dial
4			Date		Drawing No. :	1M02D000
3			Drawn			
2			Checked	T. Hiruta		
1			Approved			
Material						
Heat Treatment			General Tolerances			
Hardness			Dimensions			
Plating			Angles			

CITIZEN WATCH CO., LTD.
TOKYO, JAPAN

This drawing is provisional and subject to our reconfirmation and/or revision without notice.

*** T I P W (01) *** (2100 1121) 1M02-1UA *** 00-06-29

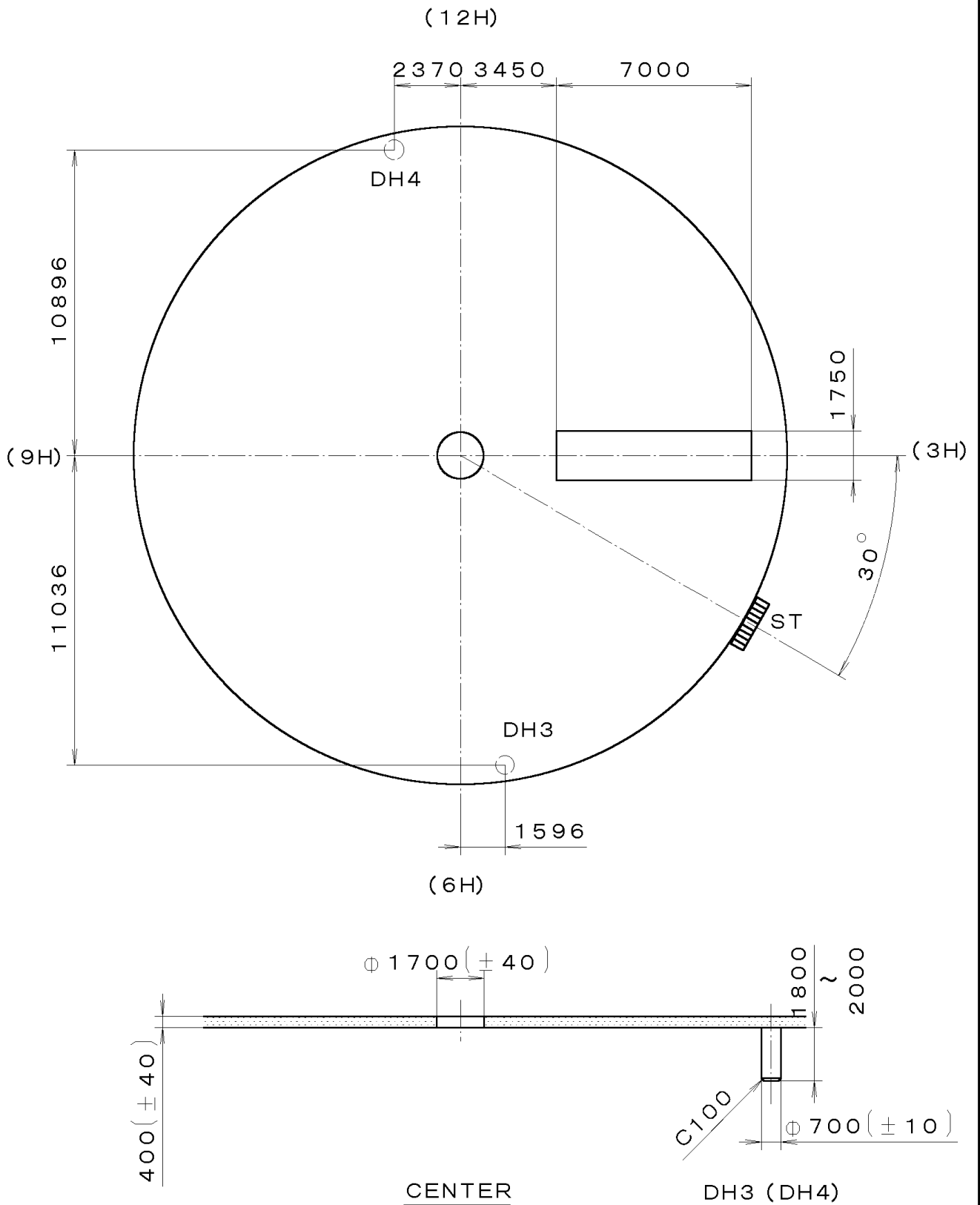

7 6 5 4 3 2 1	Quantity		Cal. No. :	1M02-1UA
	Unit	1/1000 mm	Parts:	
	Scale	5:1	Name:	Indications for Dial
	Date		Drawing No. :	1M02D010
	Drawn			
	Checked	T. Hiruta		
	Approved			
Material				
Heat Treatment		General Tolerances		
Hardness		Dimensions	CITIZEN WATCH CO.,LTD. TOKYO, JAPAN	
Plating		Angles		

This drawing is provisional and subject to our reconfirmation and/or revision without notice.

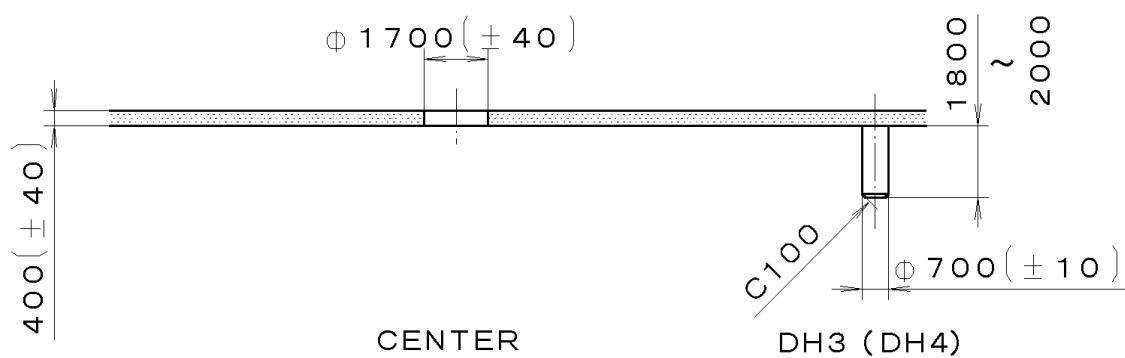
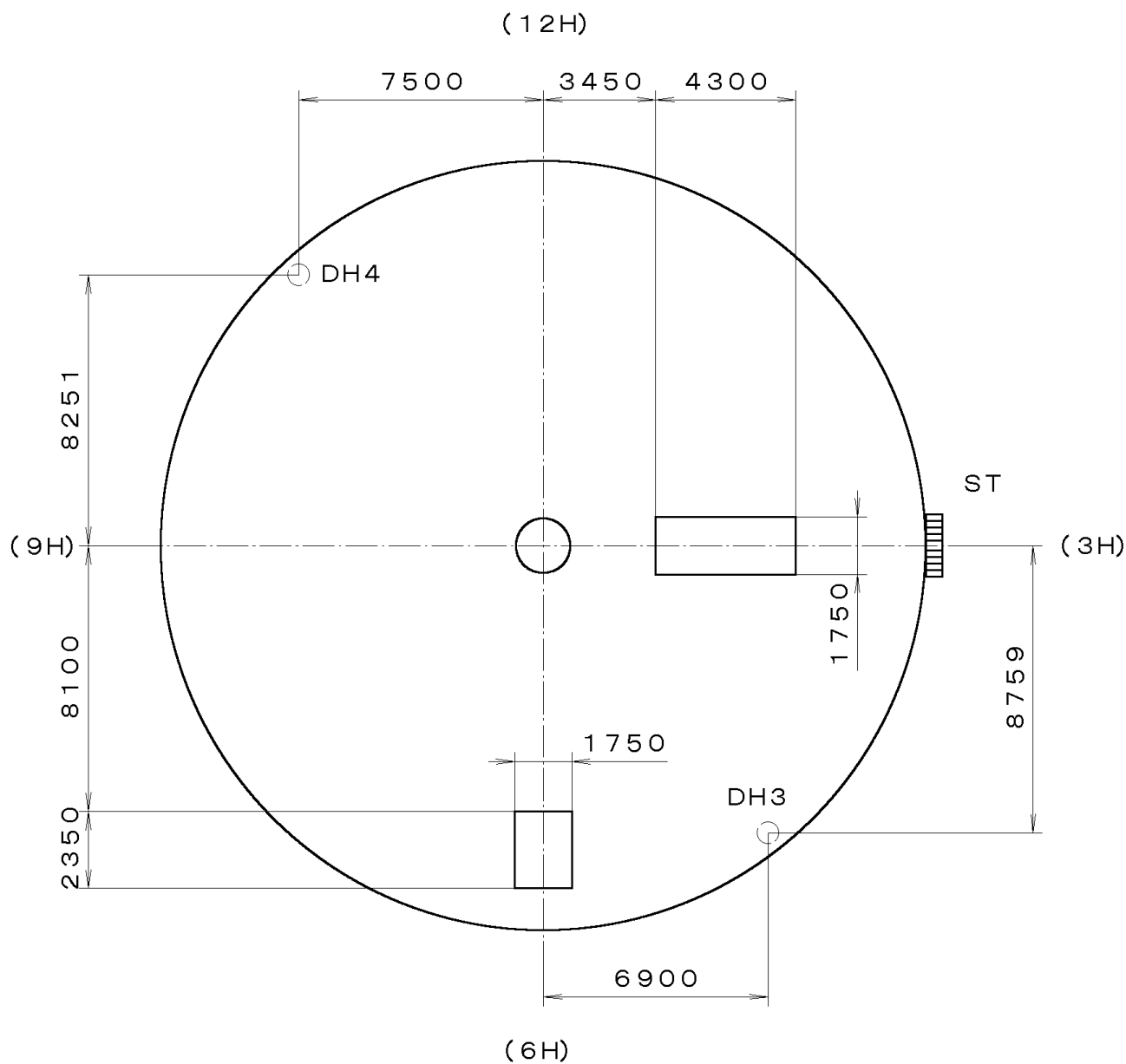

*** T I P W 1M02-1AZ (01) *** (2100 1121) 00-06-29

7			Quantity		Cal. No. :	1M02-1AZ
6			Unit	1/1000 mm	Parts:	
5			Scale	5:1	Name:	Indications for Dial
4			Date		Drawing No. :	1M02D030
3			Drawn			
2			Checked	T. Hiruta		
1			Approved			
Material					General Tolerances	
Heat Treatment					Dimensions	
Hardness					Angles	
Plating						

CITIZEN WATCH CO., LTD.
TOKYO, JAPAN

This drawing is provisional and subject to our reconfirmation and/or revision without notice.

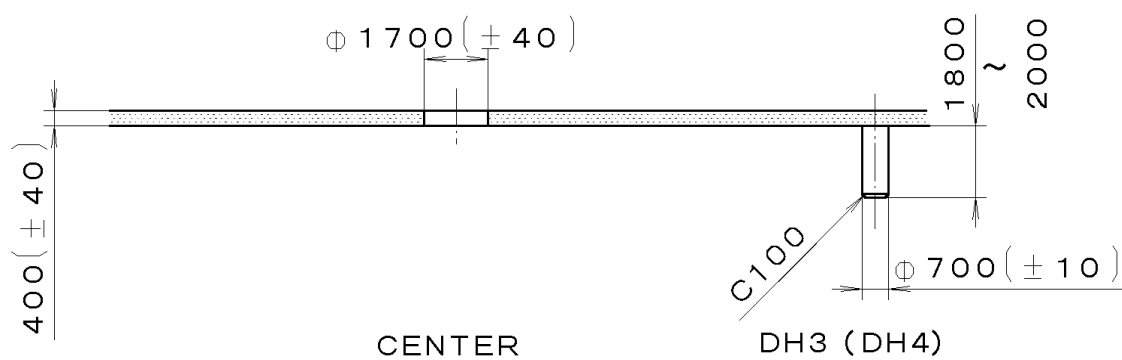
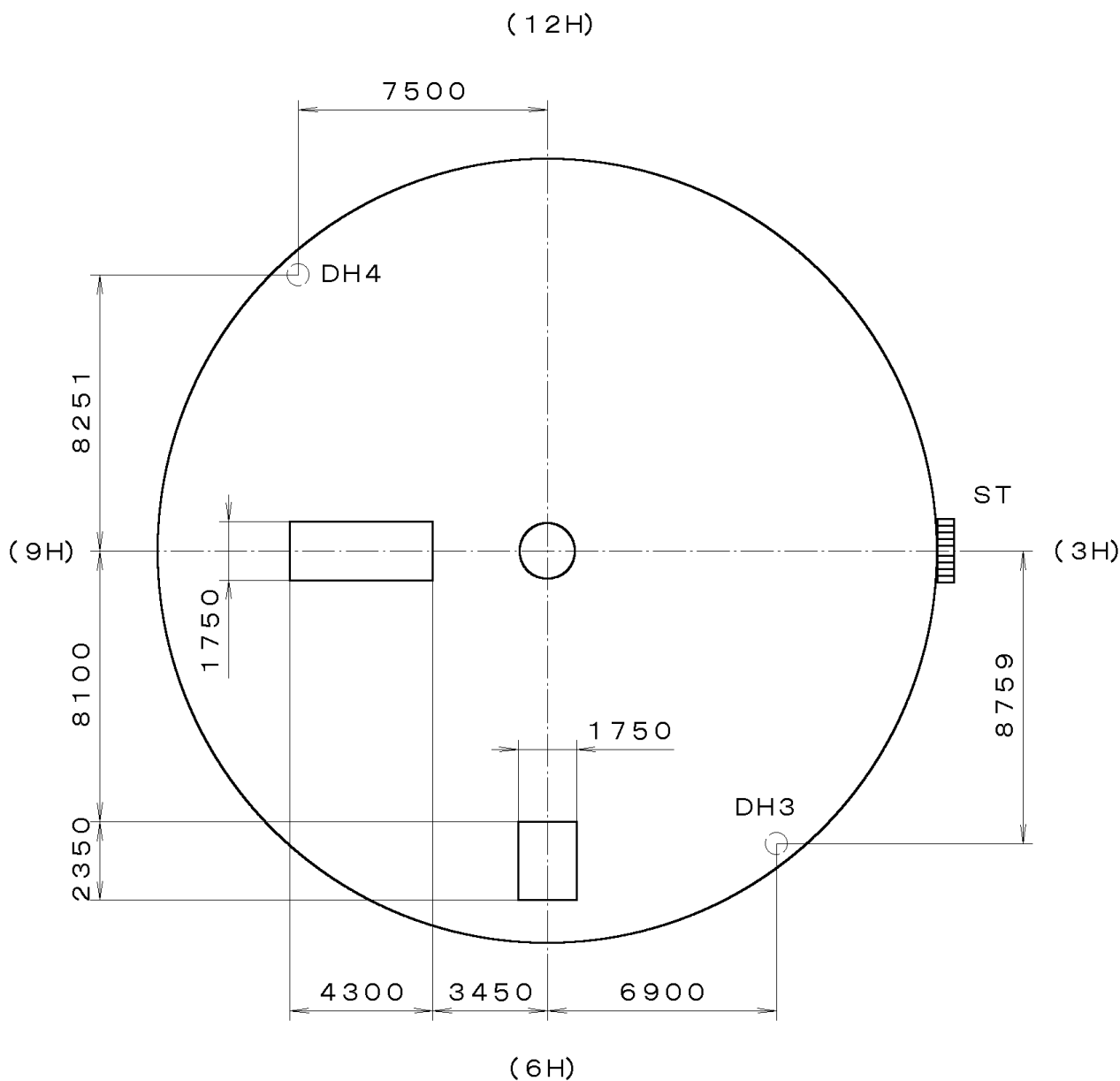

(01) 1M02-1YA (2100 1121) 00-06-29
 *** T I P W

7		Quantity		Cal. No. :	1M02-1YA
6		Unit	1/1000 mm	Parts:	
5		Scale	5:1	Name:	Indications for Dial
4		Date		Drawing No. :	1M02D060
3		Drawn			
2		Checked	T. Hiruta		
1		Approved			
Material					
Heat Treatment		General Tolerances		CITIZEN WATCH CO.,LTD. TOKYO, JAPAN	
Hardness		Dimensions			
Plating		Angles			

This drawing is provisional and subject to our reconfirmation and/or revision without notice.

*** T I P W (01) *** (2100 1121) 00-06-29

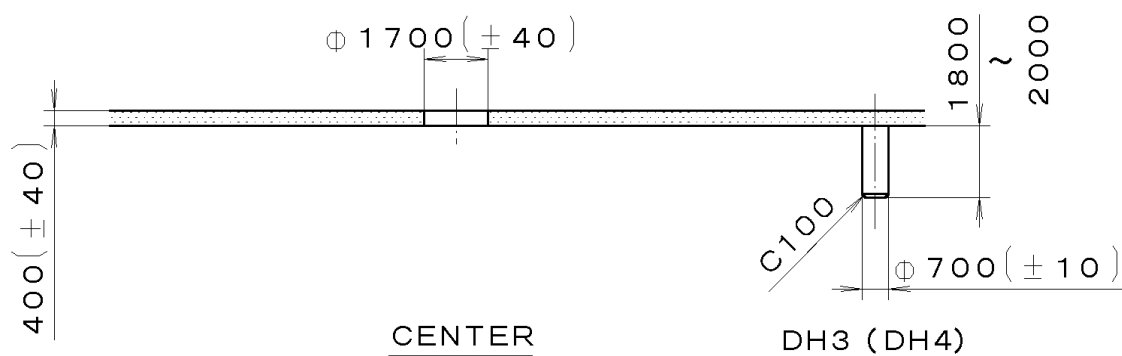
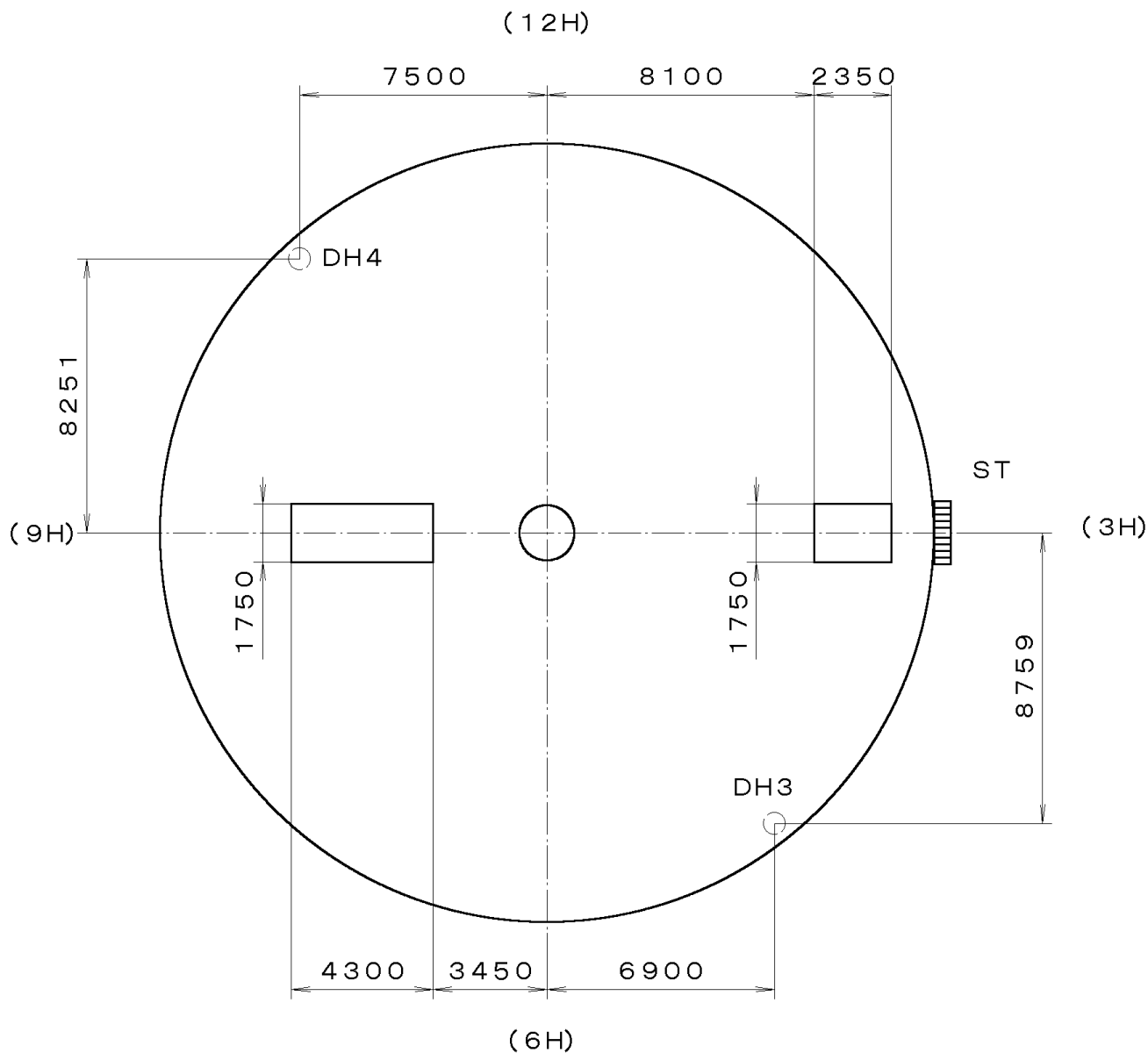

7			Quantity		Cal. No. :	1M02-1YC
6			Unit	1/1000 mm	Parts:	
5			Scale	5:1	Name:	Indications for Dial Drawing No. : 1M02D070
4			Date			
3			Drawn			
2			Checked	T. Hiruta		
1			Approved			
Material						
Heat Treatment			General Tolerances		CITIZEN WATCH CO.,LTD. TOKYO, JAPAN	
Hardness			Dimensions			
Plating			Angles			

This drawing is provisional and subject to our reconfirmation and/or revision without notice.

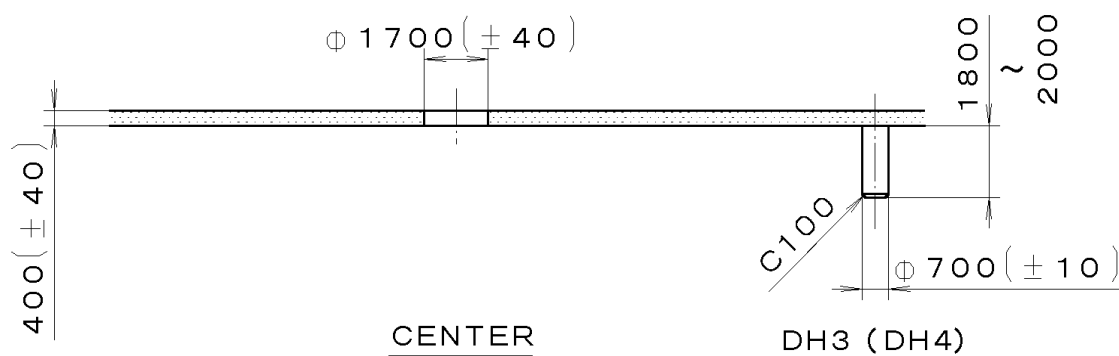
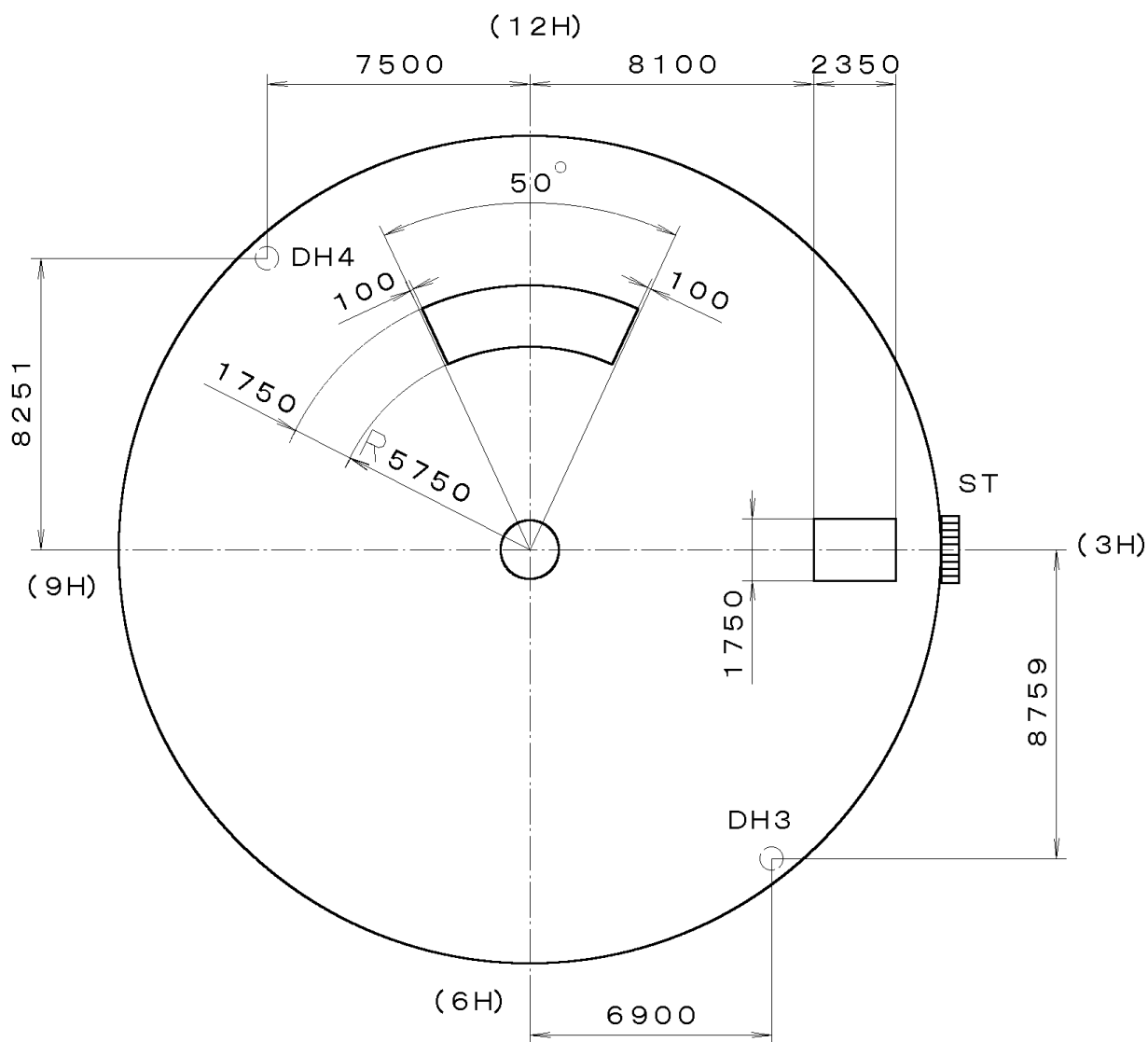

(00-06-28) (2100 1121) (01) *** 1M02-1XS *** T I P W

7			Quantity		Cal. No. :	1M02-1XS
6			Unit	1/1000 mm	Parts:	
5			Scale	5:1	Name:	Indications for Dial
4			Date		Drawing No. :	
3			Drawn			
2			Checked	T. Hiruta		
1			Approved			
Material			General Tolerances			CITIZEN WATCH CO.,LTD. TOKYO, JAPAN
Heat Treatment			Dimensions			
Hardness			Angles			
Plating						

This drawing is provisional and subject to our reconfirmation and/or revision without notice.

00-06-29) (2100 1121) (01) *** 1M02-1XY *** T I P W

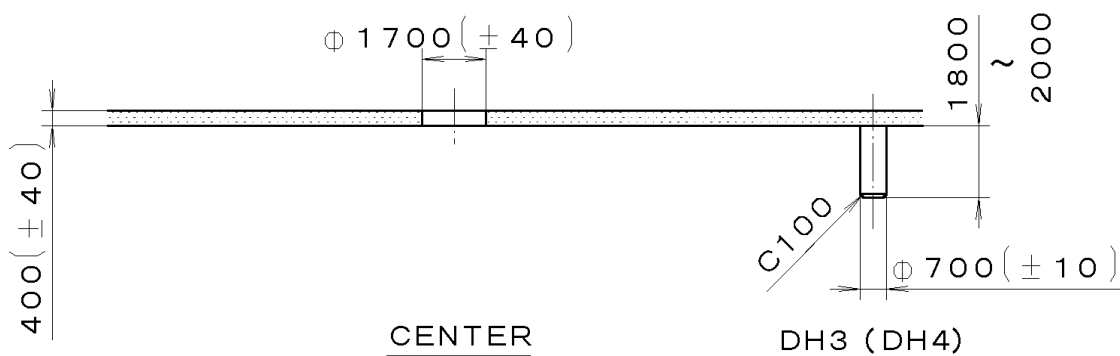
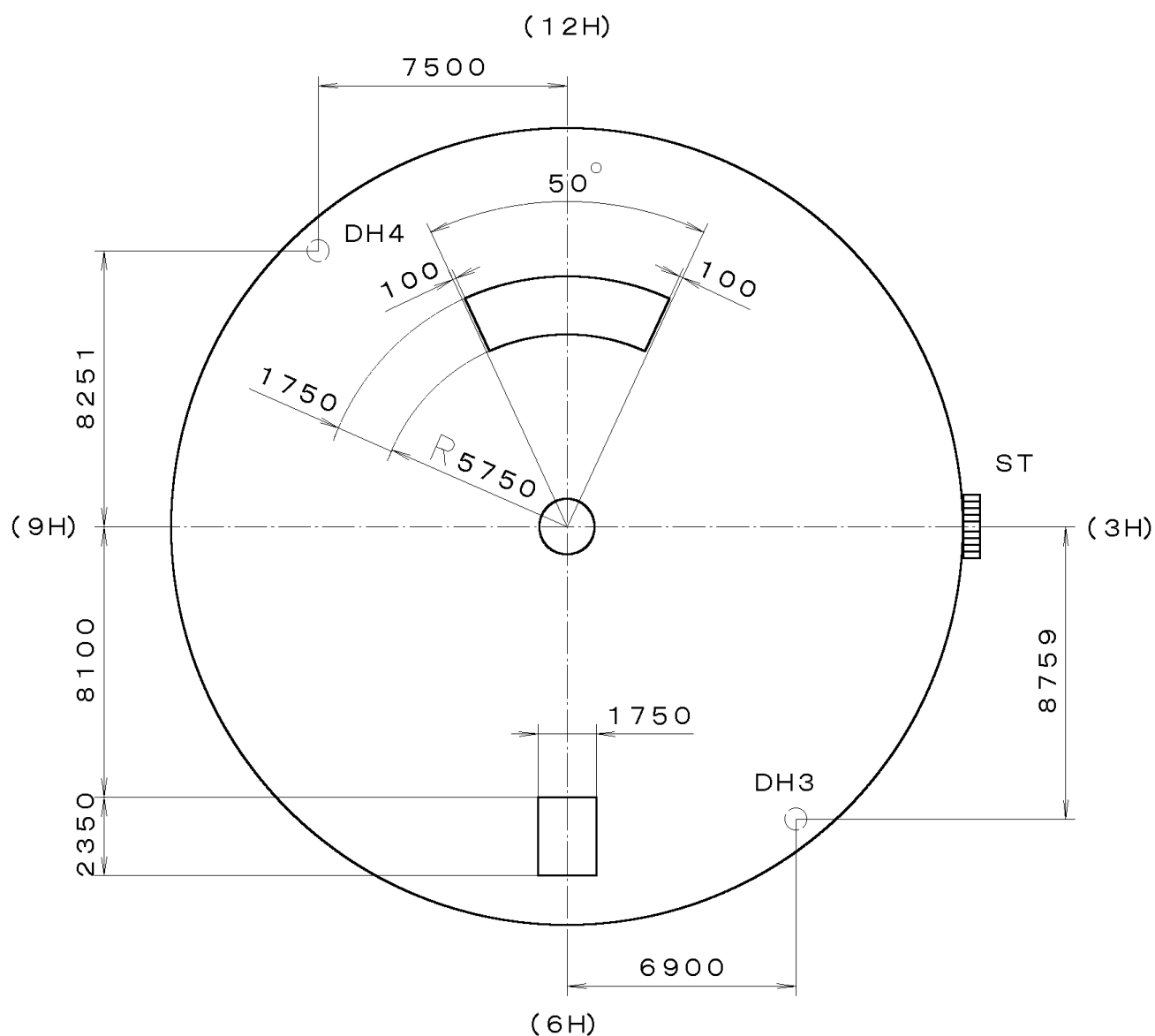

7			Quantity		Cal. No. :	1M02-1XY
6			Unit	1/1000 mm	Parts :	
5			Scale	5:1	Name :	Indications for Dial Drawing No. : 1M02D090
4			Date			
3			Drawn			
2			Checked	T. Hiruta		
1			Approved			
Material					General Tolerances	
Heat Treatment					Dimensions	
Hardness					Angles	
Plating						

CITIZEN WATCH CO., LTD.
TOKYO, JAPAN

This drawing is provisional and subject to our reconfirmation and/or revision without notice.

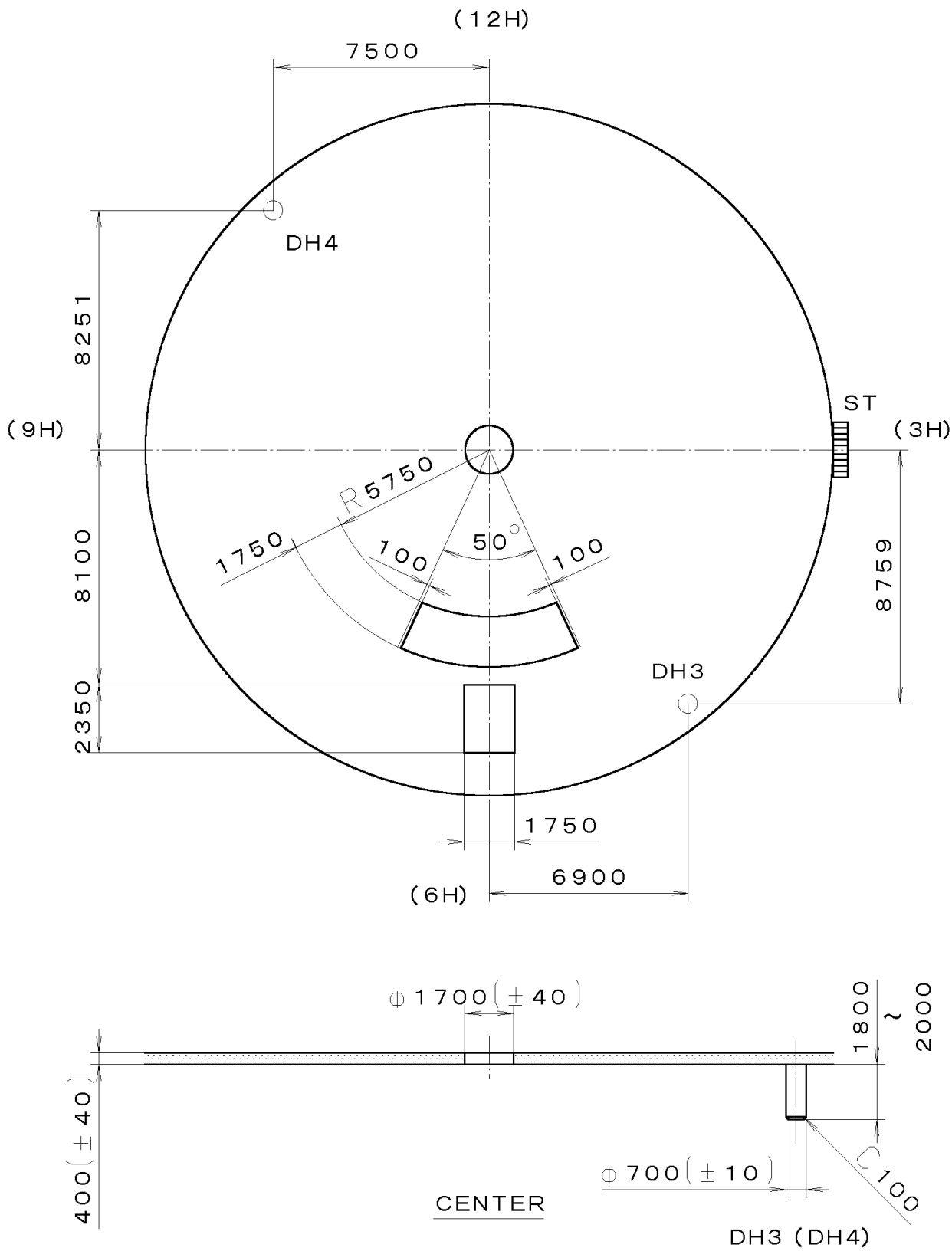

00-09-28

(2100 1121

1M02-1XX

*** T I P W

7			Quantity		Cal. No. : 1M02-1XX
6			Unit	1/1000 mm	
5			Scale	5:1	Parts:
4			Date		
3			Drawn		Name:
2			Checked	T. Hiruta	
1			Approved		Indications for Dial
Material					Drawing No. : 1M02D100
Heat Treatment			General Tolerances		CITIZEN WATCH CO., LTD. TOKYO, JAPAN
Hardness			Dimensions		
Plating			Angles		

This drawing is provisional and subject to our reconfirmation and/or revision without notice.

065-505 (01) *** (2100 1121 A-01 A-01) 00-06-22

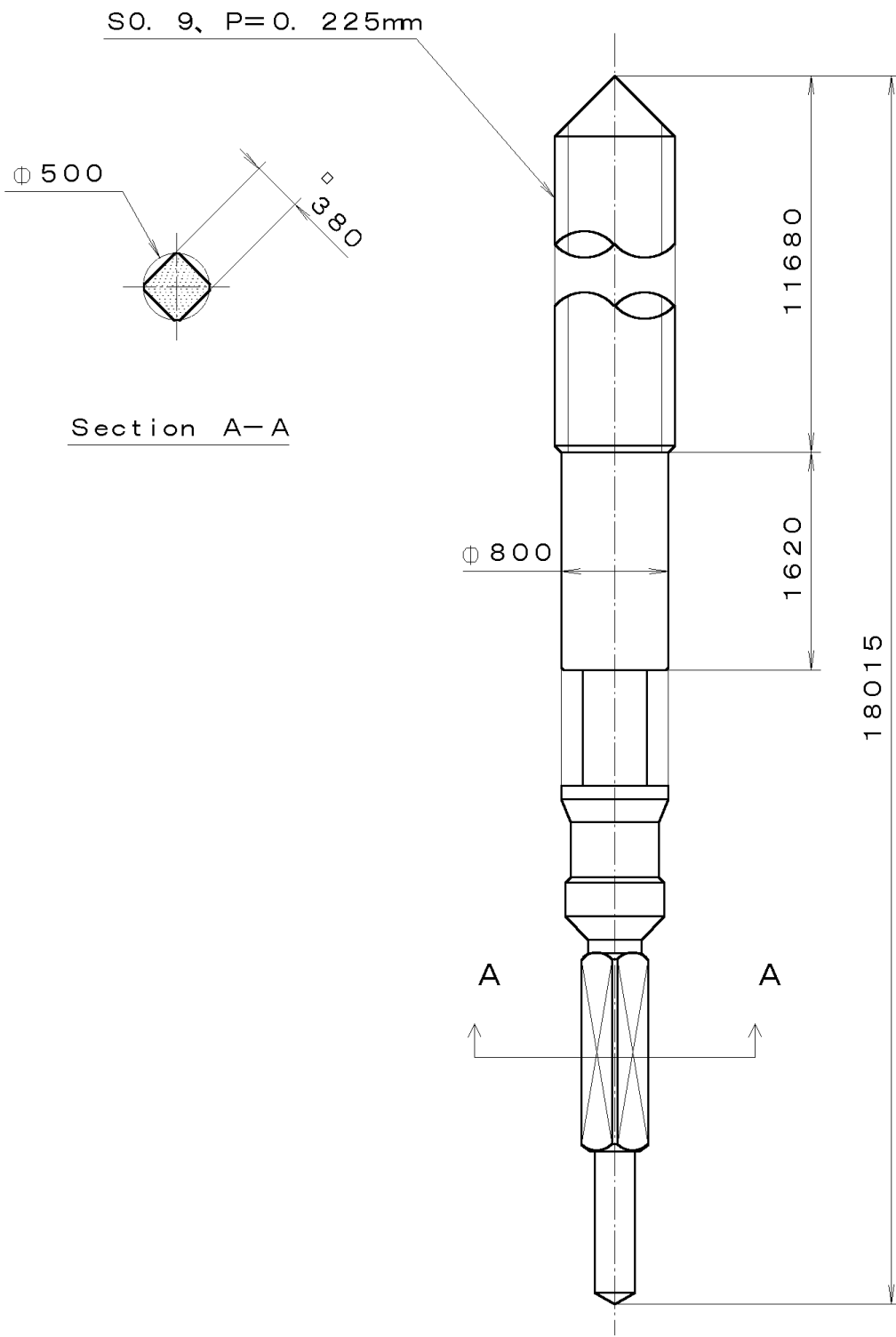

7			Quantity		Cal. No. :
6			Unit	1/1000 mm	
5			Scale	20:1	Parts:
4			Date		065-505
3			Drawn		Name:
2			Checked	T. Hiruta	SETTING STEM
1			Approved		Drawing No. : 5050S000
Material					
Heat Treatment			General Tolerances		
Hardness			Dimensions		
Plating			Angles		

CITIZEN WATCH CO., LTD.
TOKYO, JAPAN