

10 1/2'''

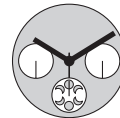

706.1



706.2

Produktion gestoppt
 Fin de série
 Phased out

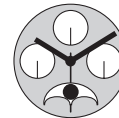

706.3



706.B

1. Werkdimensionen

1. Dimensions des mouvements

1. Movement dimensions

Kaliber	Ø Total	Ø Werksitz	Werkhöhe	Höhe Batterie	Höhe Stellwelle	Höhe Werkauflage
Calibre	Ø Total	Ø Encageage	Hauteur mouvement	Hauteur pile	Hauteur tige	Hauteur filet
Caliber	Ø Total	Ø Case fitting	Movement height	Height of battery	Height of stem	Movement rest
Einh./ Unité/ Unit	mm	mm	mm	mm	mm	mm
706.1, 706.2, 706.3	23,90	23,30	3,00	3,25	1,50	0,3
706.B	23,90	23,30	3,70	3,85	2,20	0,3
Stellwellengewinde / Filetage de la tige / Stem thread: Ø 0,90 mm				Weg / Chemin / Length of travel: 0,80 mm		

2. Funktionen

2. Fonctions

2. Functions

Kaliber	Funktionen	
Calibre	Fonctions	
Caliber	Functions	
706.1 706.2	1	Normale Position / Position normale / Running position
	2	Zeiger & Mond stellen, Sekunden-Stopp mit Unterbruch der Motorimpulse Mise à l'heure & mise lune, stop-seconde avec interruption des impulsions moteur Hand & moon setting, stop-second with interruption of motor impulses
	A ^{a)}	Schnellkorrektur Datum / Correction rapide de la date / Quick change of date
	B ^{b)}	Schnellkorrektur Wochentag / Correction rapide du jour / Quick change of day
706.3	1	Normale Position / Position normale / Running position
	2	Zeiger & Mond stellen, Sekunden-Stopp mit Unterbruch der Motorimpulse Mise à l'heure & mise lune, stop-seconde avec interruption des impulsions moteur Hand & moon setting, stop-second with interruption of motor impulses
	A ^{a)}	Schnellkorrektur Datum / Correction rapide de la date / Quick change of date
	B ^{b)}	Schnellkorrektur Wochentag / Correction rapide du jour / Quick change of day
	C ^{c)}	Schnellkorrektur Monat / Correction rapide du mois / Quick change of month
706.B	1	Normale Position / Position normale / Running position
	2	Zeiger & Mond stellen, Tag ^{b)} stellen, Sekunden-Stopp mit Unterbruch der Motorimpulse Mise à l'heure & mise lune, mise jour ^{b)} , stop-sec. avec interruption des impulsions moteur Hand & moon setting, day ^{b)} setting, stop-second with interruption of motor impulses
	A ^{a)}	Schnellkorrektur Datum / Correction rapide de la date / Quick change of date
	D ^{d)}	Schnellkorr. Kalenderwoche / Corr. rapide semaine calendrier / Quick change calendar week
Sperrzeiten für die Kalenderschnellkorrektur: 23.30–05.30 Uhr		Restrictions pour la correction rapide de la date: 23.30–05.30 heures
		Prohibitions for the quick change of the date: 23.30 pm–05.30 am

Werkaufbau

Assemblage

Assembling

10 1/2''' 706.1

10 1/2''' 706.1, **706.2***

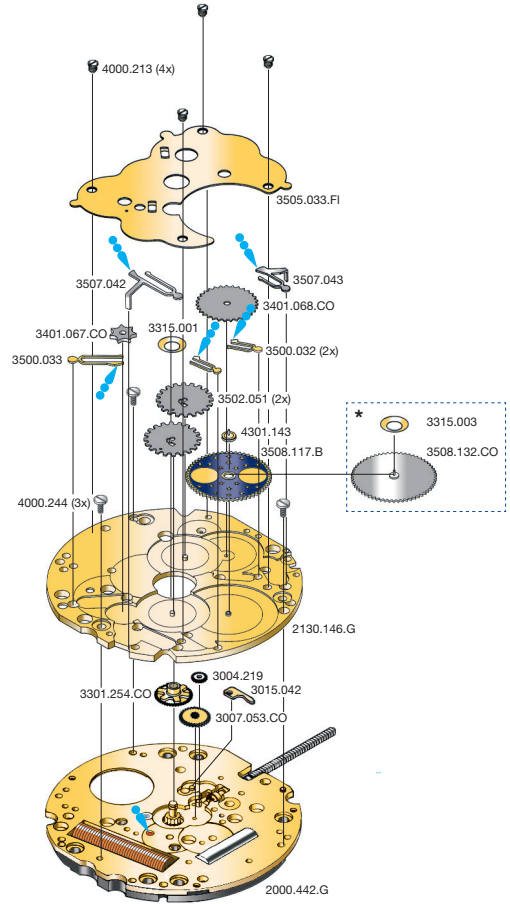
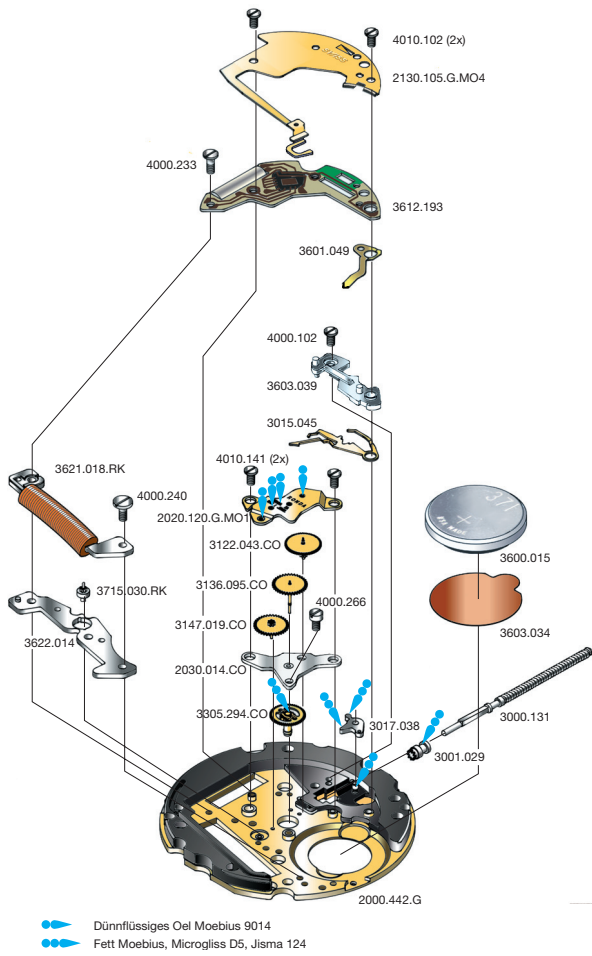

Cal. 706.1, 706.2 , 706.3 Werkseite / Côté mouvement / Movement side			
Plan No.	Bestandteile	Fournitures	Spare Parts
2000.442.G	Werkplatte	Platine	Main plate
2020.120.G.M01	Räderwerkbrücke	Pont rouge	Train w. bridge
2030.014.CO	Zentrumbrücke	Pont centre	Centre bridge
2130.105.G.M04	Modul-Abdeckp.	Couvre module	Module cover pl.
3000.131	Stellwelle	Tige	Stem
3001.029	Kupplungstrieb	Pignon coulant	Sliding pinion
3015.045	Wippe	Bascule	Yoke
3017.038	Winkelhebel	Tirette	Setting lever
3122.043.CO	Kleinbodenrad	Roue moyenne	Third wheel
3136.095.CO	Sekundenrad	Roue secondes	Second-wheel
3147.019.CO	Zwischenrad	Roue interméd.	Intermed. wheel
3305.294.CO	Minutenrohr	Chaussée	Cannon pinion
3600.015	Batterie	Pile	Battery
3601.049	Batterie-Kontakt	Bride contact	Battery contact
3603.034	Batterie-Isolation	Isolateur pile	Battery insulation
3603.039	Deckplatte	Couvre mécan.	Setting lev. cover
3612.193	Modul	Module	Module
3621.018.RK	Spule	Bobine	Coil
3622.014	Stator	Stator	Stator
3715.030.RK	Rotor	Rotor	Rotor
4000.102	Vis	Schraube	Screw
4000.233	Schraube	Vis	Screw
4000.240	Schraube	Vis	Screw
4000.266	Schraube	Vis	Screw
4010.102	Schraube	Vis	Screw
4010.141	Schraube	Vis	Screw

Abweichungen / Divergences / Deviations

Cal. 706.B Werkseite / Côté mouvement / Movement side			
Plan No.	Bestandteile	Fournitures	Spare Parts
2030.013.CO	Zentrumbrücke	Pont centre	Centre bridge
3136.100.CO	Sekundenrad	Roue secondes	Second-wheel
3305.295.CO	Minutenrohr	Chaussée	Cannon pinion
3612.103	Modul	Module	Module
3622.023	Stator	Stator	Stator
3715.089.CO	Rotor	Rotor	Rotor

Batterien / Piles / Batteries

706.1-706.B	Nr. 371 Dim. Ø x H:	SR 920 SW 9,50 x 2,06
-------------	------------------------	--------------------------

Werkaufbau

Assemblage

Assembling

10 1/2''' 706.3

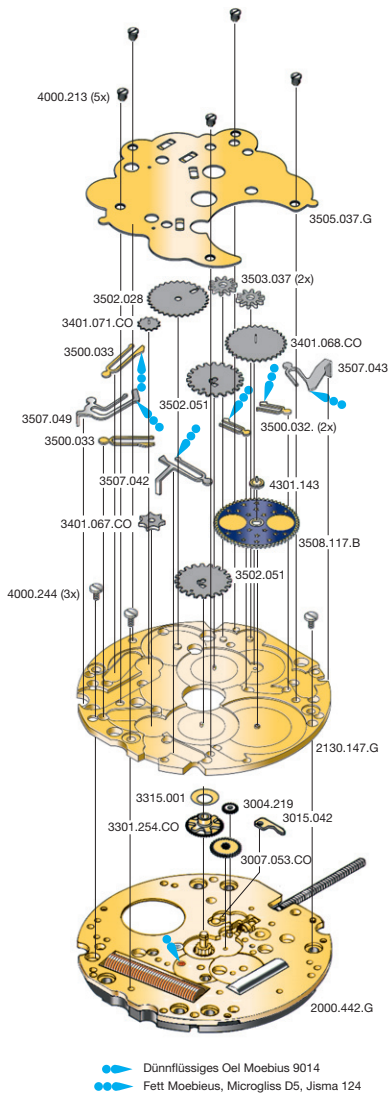

10 1/2''' 706.B

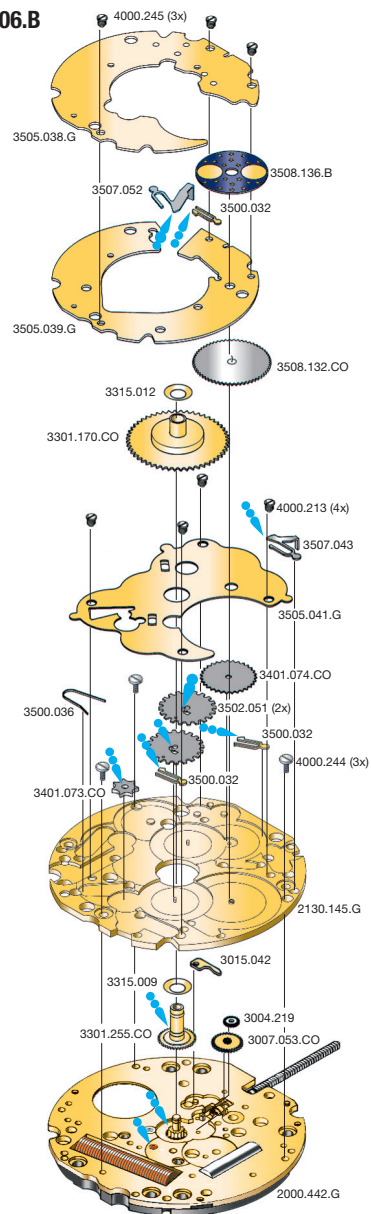

Cal. 706.1 Zifferblattseite / Côté cadran / Dial side			
Plan No.	Bestandteile	Fournitures	Spare Parts
2130.146.G	Kalenderplatte	Plaque calendrier	Date ind. plate
3004.219	Zeigerstellrad	Renvoi minuterie	Setting wheel
3007.053.CO	Wechselrad	Minuterie	Minute wheel
3015.042	Wippe unten	Bascule dessous	Second yoke lower
3301.254.CO	Stundenrad	Canon	Hour wheel
3315.001	Spreizfeder 2 1/2	Clinquant 2 1/2	Washer 2 1/2
3401.067.CO	Wochentagrad	Roue de jour	Day wheel
3401.068.CO	Datumrad	Roue quantième	Date wheel
3500.032	Hebelfeder	Ressort	Moon and date jumper spring
	Mond / Datum	quantième & lune	
3500.033	W.-tagradklinke	Sautoir jour	Day jumper spring
3502.051	Schaltr. f. Datums.	Roue entraineuse	Date ind. driv. wh.
3505.033.FI	Deckplatte	Couvercle	Cover plate
3507.042	Drücker Datums.	Correcteur jour	Pusher day
3507.043	Drücker Datums.	Correcteur quant.	Pusher date
3508.117.B	Mondscheibe	Disque lune	Moon indicator
4000.213	Schraube	Vis	Screw
4000.244	Schraube	Vis	Screw
4301.143	Niete für Mond	Plot	Rivet of moon

Abweichungen / Divergences / Deviations

Cal. 706.2 Zifferblattseite / Côté cadran / Dial side			
Plan No.	Bestandteile	Fournitures	Spare Parts
3315.003	Spreizfeder	Clinquant	Washer
3508.132.CO	Mondscheibe	Disque lune	Moon indicator

Abweichungen / Divergences / Deviations

Cal. 706.3 Zifferblattseite / Côté cadran / Dial side			
Plan No.	Bestandteile	Fournitures	Spare Parts
2130.147.G	Kalenderplatte	Plaque calendrier	Date ind. plate
3401.071.CO	Monatsrad	Roue de mois	Month wheel
3502.028	Mitnehmerad Mt.	Entraineur mois	Month finger driv.
3503.037	Zwischenrad Mt.	Renvoi mois	Setting wheel mt.
3505.037.G	Deckplatte	Couvercle	Cover plate
3507.049	Korrektor Monat	Correcteur mois	Corrector month

Cal. 706.B Zifferblattseite / Côté cadran / Dial side			
Plan No.	Bestandteile	Fournitures	Spare Parts
2130.145.G	Kalenderplatte	Plaque calendrier	Date ind. plate
3301.170.CO	Stundenrad 52W	Canon 52W	Hour wheel 52W
3301.255.CO	Stundenrad	Canon	Hour wheel
3315.009	Spreizfeder	Clinquant	Washer
3315.012	Spreizfeder 3 1/2	Clinquant 3 1/2	Washer 3 1/2
3401.073.CO	Tagesrad 52W	Roue jour 52W	Day wheel 52W
3401.074.CO	Datumrad 52W	Roue quant. 52W	Date wheel 52W
3500.036	Feder Tagesrad	Ressort jour	Day spring
3505.038.G	Deckplatte 52W	Couvre plaq. 52W	Cover plate 52W
3505.039.G	Halteplatte 52W	Plaque 52W	Maint. plate 52W
3505.041.G	Deckplatte 52W	Couvercle 52W	Cover plate 52W
3507.052	Korrektor 52W	Correcteur 52W	Corrector 52W
3508.132.CO	Mondscheibe	Disque lune	Moon indicator
3508.136.B	Mondscheibe	Disque lune	Moon indicator
4000.245	Schraube	Vis	Screw

3. Leistungen

3. Performances

3. Performances

Kaliber Calibre Caliber	Bedingungen Conditions Conditions	Momentaner Gang Marche instantanée Instantaneous rate	Stromaufnahme Consommation courant Power consumption	Drehmoment Couple utile Torque	Gangreserve (theoretisch) Autonomie (theoretique) Autonomy (theoretical)
Einheit / Unité / Unit Typ.Wert / Valeur / value		(s/month)	(μ A) typ. max.	(μ Nm) typ. sec. min.	(Monat/mois/month)
706.1–706.3	1,55 V 23°C	- 10/+ 20	0,8 1,35	8 400	60
706.B	Batt./ Pile 43 mAh	- 10/+ 20	1,37 2,25	12 600	44
Magnetfeldabschirmung / Résist. aux champs magn. / Resist. to magnetic fields			18,8 Oe	1500 A/M	
Betriebstemperatur / Température d'opération / Operating temperature			0–50°C		Norm 
Schockresistenz / Résistance au choc/ Shock resistance			NIHS 91–10		

Anzeige Ende der Batterielaufzeit EOL

Der Sekundenzeiger hält während 4 Sekunden an und holt dann die 4 Sprünge kurzfristig nach.

Indication de fin de vie de pile EOL

L'aiguille de secondes s'arrête durant 4 secondes puis fait rapidement 4 pas.

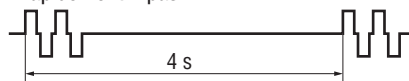

Battery end-of-life indication EOL

The second-hand stops for 4 seconds before executing rapidly the 4 steps.

Folgende Kaliber sind mit dem EOL-System ausgerüstet:

Les calibres suivants sont munis du système EOL:

The following calibers are equipped with EOL:

Swiss Made 10 1/2^{'''} – 706, **706.2**, 706.3, 706.B

4. Elektr. Messungen

4. Contrôles électriques

4. Electrical checking

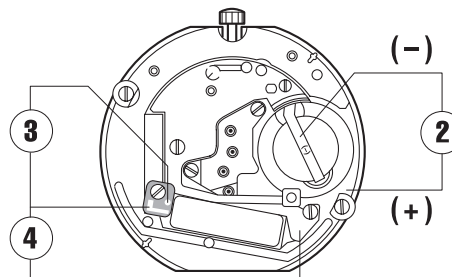
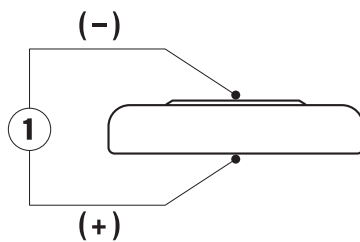

Kaliber Calibre Caliber	Pos. Pos. Pos.	Einheit Unité Unit	Messwerte Valeurs mesurées Measured values	Kontrolle Contrôle Check	Bemerkungen Remarques Remarks
706.1–706.B	1	V	1,55	Batterie-Spannung Tension de la pile Battery voltage	Batterie herausnehmen und messen Enlever et mesurer la pile Remove battery for measuring
706.1–706.3 706.B	2	μ A	0,8/1,35 1,37/2,25	Stromaufnahme typisch/ maximum Consom. de courant typique/ maximum Power consumption typical/ maximum	Ohne Batterie, mit externer Speisung Sans pile, avec alimentation externe Without battery, with external power supply
706.1–706.B	2	V	\leq 1,30	Funktionskontrolle bei Minimalspannung Contrôle de fonctionnement à tension minimale Check with lowest possible voltage	Ohne Batterie, mit externer Speisung Sans pile, avec alimentation externe Without battery, with external power supply
706.1–706.B	3	K Ω	1,75–1,95	Spulenwiderstand Résistance de la bobine Resistance of the coil	Ohne Batterie Sans pile Without battery
706.1–706.B	4	K Ω	∞	Spulenisolation Isolation de la bobine Coil insulation	Ohne Batterie Sans pile Without battery
706.1–706.B		Sek./Monat sec./mois sec./month	- 10/+ 20	Induktivsonde 60 Sek. Senseur inductif 60 sec. Inductive sensor 60 sec.	Mit Batterie Avec pile With battery

5. Zeigerwerk

5. Aiguillage

5. Dial-train

Kaliber Calibre Caliber	Zeigerwerk Aiguillage Height of dial train	Einzelteil-Höhe mm					Höhe ab Zifferblattauflage mm				Ø Zeigeranpassung mm					Zifferblatticke mm
		Hauteur de la pièce ind. mm					Dépassement platine mm				Ø Adjust. des aiguilles mm					Epaisseur
		Height of individ. piece mm					Height from base mm				Ø Adjustm. of hands mm					du cadran mm
	No.	A	B	C	D	W	E	F	G	RS	H	I	J	K	L	Dial thickness mm
706.1																
706.2	1	3,12	2,10	4,79	2,09	–	1,43	1,13	1,84	–	1,20	0,70	0,20	0,20	–	0,40
706.3																
706.B	1	4,79	3,76	6,45	3,60	2,32	2,40	2,09	2,80	1,39	1,20	0,70	0,20	0,20	1,80	0,40

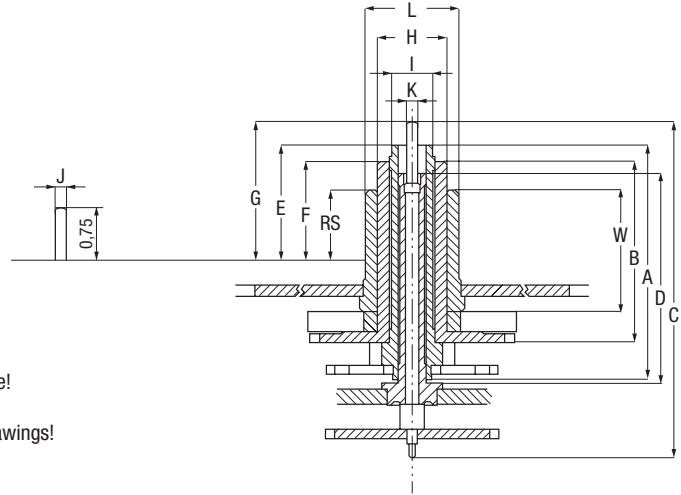

Für Einzelheiten verlangen Sie bitte die entsprechenden Zeigerwerkpläne!
 Pour plus de détails demandez nos plans d'aiguillage!
 For more detailed information please ask for the corresponding hand drawings!

6. Einschalen/Werkzeuge

6. Emboîtement/outils

6. Casing/tools

706.1, 706.2, 706.3, 706.B

Nr. H 70X.1A



706.1, 706.2, 706.3

Nr. H 706.1U



706.B

Nr. H 706B.1U

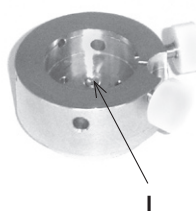

706.1, 706.2, 706.3, 706.B

Nr. H 70X.1T



	SWISS MADE	SWISS PARTS
Schraube Vis Screw I		
Schraube Vis Screw II		

Zeigersetzen

Maximale Aufpresskraft:

- Stunden und Minutenzeiger: max. 40N
- Alle andern Zeiger: max. 30N

Beim Zeigersetzen muss das Werk abgestützt werden.

Poser les aiguilles

Force de chassage maximale:

- Aiguilles des heure et des minutes: max. 40N
- Toutes autres aiguilles: max. 30N

Lors de la pose d'aiguilles, le mouvement doit être soutenu.

Hand setting

Maximal force:

- Hour and minute hands: max. 40N
- All other hands: max. 30N

The movement needs to be supported for hand setting.

Stellwelle entfernen

Beim Entfernen der Stellwelle muss sich die Stellwelle in Position 1 (gedrückt) befinden, bevor auf den Winkelhebel gedrückt wird.

Enlever la tige

En enlevant la tige, la tige doit se trouver en position 1 (poussée), avant de pousser sur la tirette.

Stem removal

For removal of the stem, the stem must be pushed into position 1 (pressed in) prior to apply pressure to the setting lever.

10 1/2''' 706.1, 706.2, 706.3

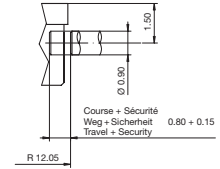
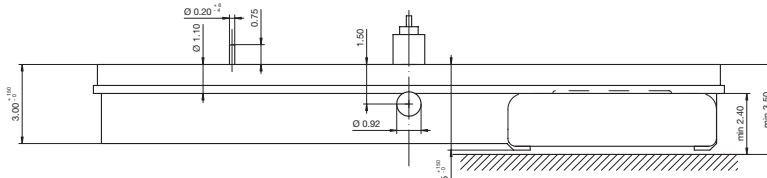
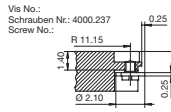
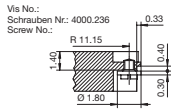

Seite Gehäuseboden
Côté fond de boîte
Case back side

Zifferblattseite
Côte cadran
Dial side

Zifferblattfüsse
Pieds de cadran
Dial feet

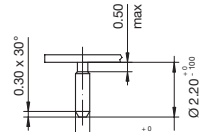
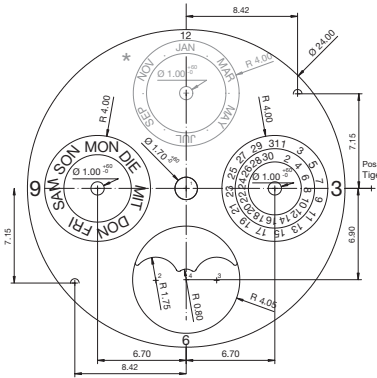
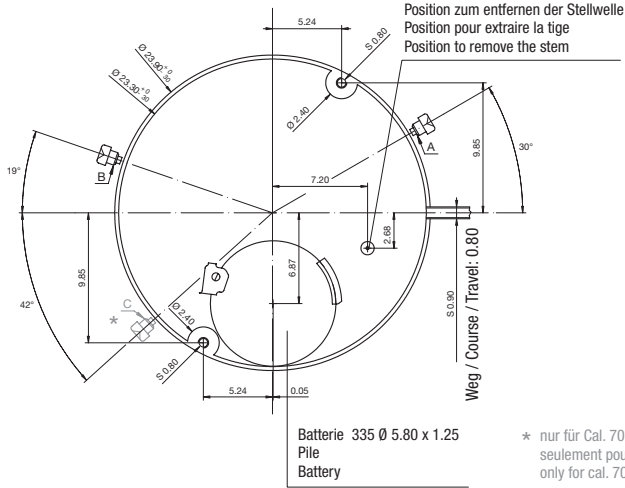

* nur für Cal. 706.3
seulement pour cal. 706.3
only for cal. 706.3

10 1/2''' 706.B

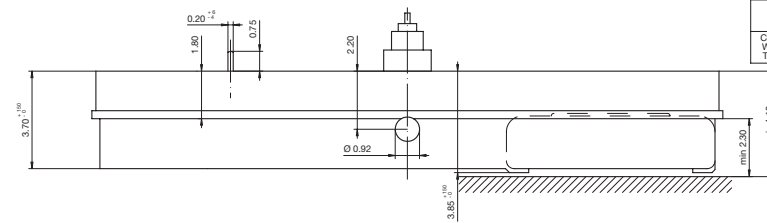
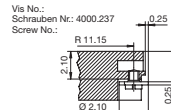
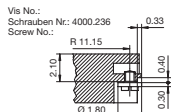

Correcteur Korrektor Corrector	A	D
Course + Sécurité Weg + Sicherheit Travel + Security	0.80 + 0.15	0.60 + 0.10

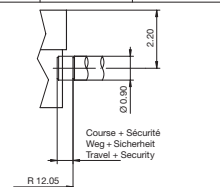

Seite Gehäuseboden
Côté fond de boîte
Case back side

Zifferblattseite
Côte cadran
Dial side

Zifferblattfüsse
Pieds de cadran
Dial feet

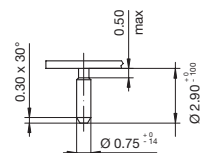
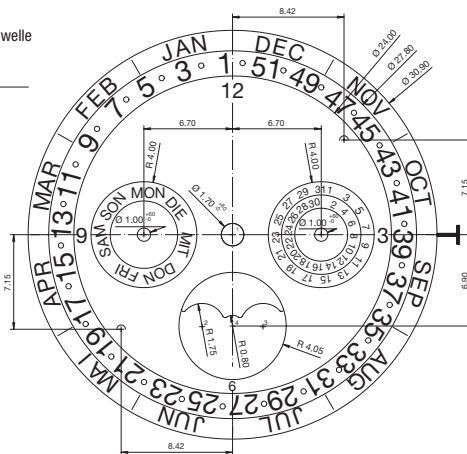
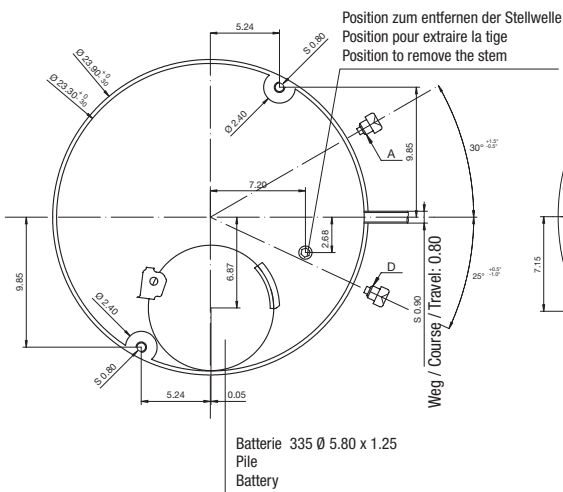

Sicherheit zwischen Minutenzeiger und Glas
Sécurité entre l'aiguille des minutes et le verre
Security between minute hand and glass

min. 0,30 mm
min. 0,30 mm
min. 0,30 mm

Das Zifferblatt muss durch die Schale gehalten werden.
Le cadran doit être tenu par la boîte.
The dial must be hold by the case.